

Features

- Operating voltage:2.4-5.5V
- Standby current: 8uA/3.0V
- Operating current:60uA/3.0V
- Power-On Reset (POR)
- Low Voltage Reset (LVR)
- Key Response Time:
 - Normal Mode 60mS
 - Standby Mode 160mS
- CMOS-Direct Output
- Provide active High or active Low by AHLB pin option
- Sensitivity adjustment using an external capacitor(1-47nF) on CS pin
- Add a capacitor (0-50pF) to a touch key pin can fine tune the sensitivity for single key
- After power-on have about 0.25S stable-time, during the time do not touch the key .

- Package:
SOP8 (150mil)((4.9mm x 3.9mm PP=1.27mm)

1 General Description

VK3602K is a touch pad detector IC which offers 2 touch keys,It can detect human body contact using external touch pads. The high level of device integration enable applications to be implemented with a minimum number of external components.

It has 2 CMOS-Direct Output pin. Special internal circuitry is also employed to ensure excellent power noise rejection to reduce the possibility of false detections, increasing the touch switch application reliability under adverse environmental conditions.

With auto-calibration, low standby current, excellent resistance to voltage fluctuation and other features, this range of touch key devices provide a simple and effective means of implementing 2 touch key + IO operation in a wide variety of applications.

2 Pinouts and pin description

2.1 VK3602KSOP8 Pin Assignment

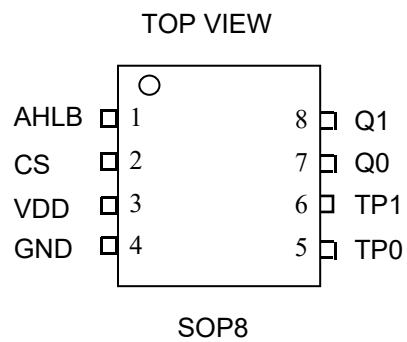

2.2 VK3602K SOP8 Pin Description

Pin No.	Pin name	I/O	Function Description
1	AHLB	IN	Built in pull-up resistor ,Output level selection: 0->active High 1->active Low (default)
2	CS	IN	Capacitance detection,the larger the capacitance the higher the sensitivity(1-47nF)
3	VDD	VDD	Positive power supply
4	GND	GND	Negative power supply
5	TP0	IN	Touch key input pin
6	TP1	IN	Touch key input pin
7	Q0	OUT	Touch key output pin
8	Q1	OUT	Touch key output pin

3 Functional Description

3.1 Block diagram

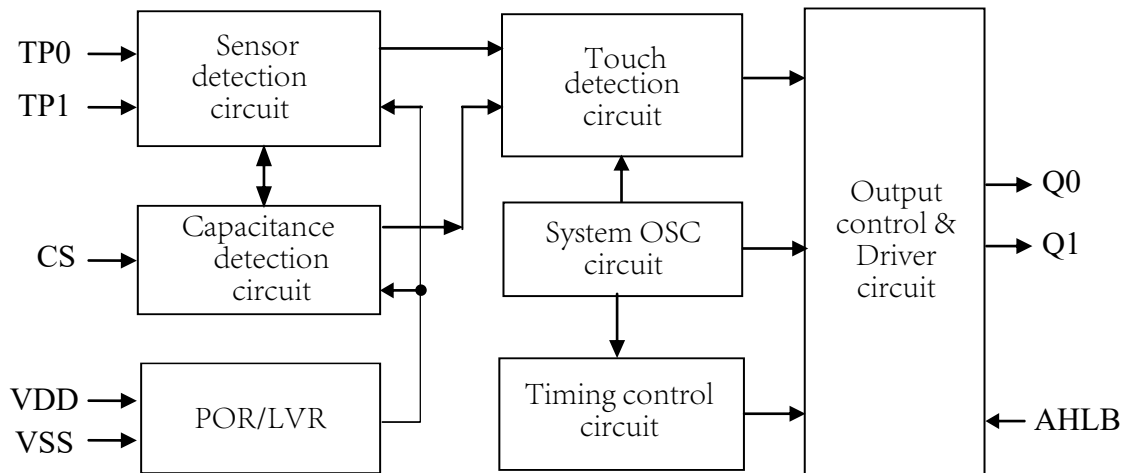

3.2 Output mode

CMOS Direct output(Q0~Q1)

AHLB selects the effective level of output: 0->Active High 1->Active Low(default)

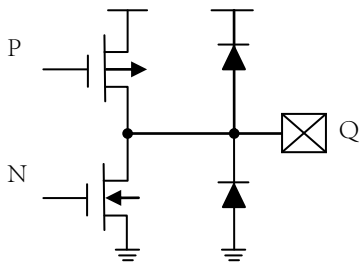

3.3 Operating Mode

There are two operating modes for VK3602K, the normal mode and the standby mode. If any key is pressed, the device will be waken up and will then enter the normal mode. If no key press, After 4S, the system will then return to the standby mode again, it will be saving power. When VDD=5V at standby mode output response time about 160ms, at detective mode output response time about 60 ms.

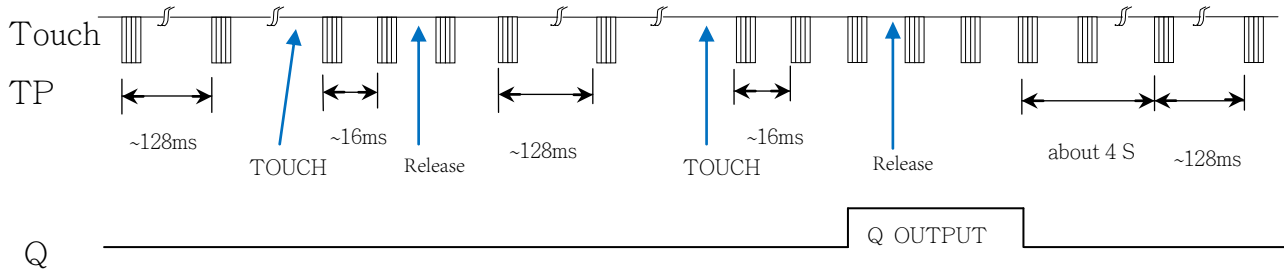

3.4 Sensitivity Adjustment

The touch PAD size and capacitance of connecting line on PCB can affect the sensitivity. The sensitivity adjustment must according to the practical application on PCB. The VK3602K offers some methods for adjusting the sensitivity outside:

I. Touch PAD Size

Under other conditions are fixed. Using a larger Touch PAD size can increase sensitivity. Otherwise it can decrease sensitivity. But the touch PAD size must use in the effective scope.

II. Panel Thickness

Under other conditions are fixed. Using a thinner panel can increase sensitivity. Otherwise it can decrease sensitivity. But the panel thickness must be below the maximum value.

III. Value of CS

Under other conditions are fixed. CS pin to VSS capacitor Cs can adjust sensitivity, When adding the value of CS will increase sensitivity in the useful range (1nF-47nF) .

IV. Capacitor to a touch key pin

Add a capacitor (0-50pF) to a touch key can fine tune the sensitivity for single key, When adding the value of capacitor will decrease sensitivity .

Panel Thickness (Acrylic or Glass)	CS value (only reference)
<3mm	6.8nF/25V
3-6mm	10nF/25V
6-10mm	22nF/25V

4 Application Circuits

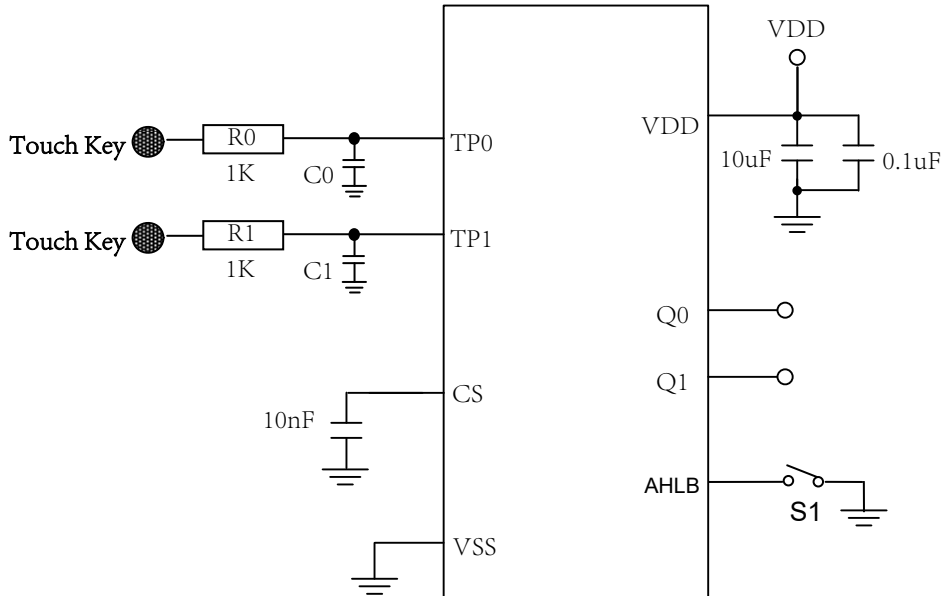

5 Electrical characteristics

5.1 Absolute Maximum Ratings

Item	Symbol	Ratings	Unit
Power voltage	VDD	-0.3~6.0	V
Input Voltage	VIN	$V_{SS}-0.3\sim V_{DD}+0.3$	V
Storage Temperature	TSTG	-50~+125	°C
Operating Temperature	TOTG	-40~+85	°C
Human Body Mode	ESD	≥ 4	KV

5.2 DC Characteristics

Item	Symbol	Min.	Typ.	Max.	Unit	Test Conditions (25 °C)	
						VDD	Conditions
Operating voltage	VDD	2.4	3.0	5.5	V	—	—
Operating current	I _{OP}	—	60	120	μA	3.0V	CS=10nF
		—	120	240		5.0V	
Standby current	I _{ST}	—	8	16	μA	3.0V	CS=10nF
		—	20	40		5.0V	
Output Sink Current	I _{IL}	—	8.0	—	mA	3.0V	V _{OL} =0.5V
		—	12.0	—		5.0V	
Output Source Current	I _{OL}	—	-3.5	—	mA	3.0V	V _{OH} =2.8V
		—	-5.0	—		5.0V	V _{OH} =4.5V
Input Low Voltage	V _{IL}	—	—	1/3	VDD	VDD	Input Low Voltage
Input High Voltage	V _{IH}	2/3	—	1	VDD	VDD	Input High Voltage
Output Response Time	T _R	—	60	—	mS	3.0V	normal mode
		—	60	—		5.0V	normal mode
		—	160	—	mS	3.0V	standby mode
		—	160	—		5.0V	standby mode

6 Package Information

6.1 SOP8(150mil)(4.9mm x 3.9mm PP=1.27mm):

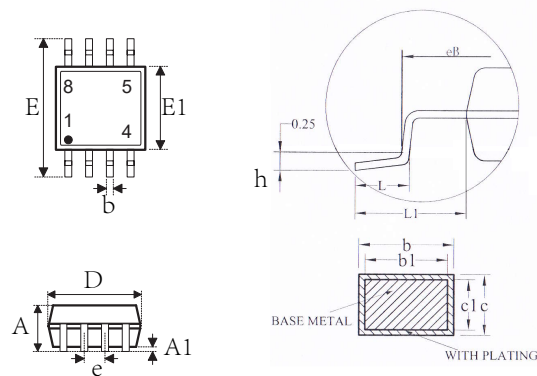

SYMBOL	MILLIMETER		
	MIN	NOM	MAX
A	---	---	1.75
A1	0.10	---	0.225
b	0.39	---	0.47
b1	0.38	0.41	0.44
c	0.20	---	0.24
c1	0.19	0.20	0.21
D	4.80	4.90	5.00
E	5.80	6.10	6.20
E1	3.80	3.90	4.00
e	1.27BSC		
h	0.25	---	0.50
L	0.50	---	0.80
L1	1.05REF		

7 Revision history

No.	Version	Date	Modify the content	Check
1	1.0	2018-08-10	Original version	Yes
2	1.1	2020-02-11	Update content	Yes

Disclaimers

Information in this document is believed to be accurate and reliable. However, VinKa does not give any representations or warranties, expressed or implied, as to the accuracy or completeness of such information. VinKa reserves the right to make changes to information published in this document, including without limitation specifications and product descriptions, at any time and without notice. This document supersedes and replaces all information supplied prior to the publication hereof. For the latest information, please visit <https://www.szvinka.com> Or contact VinKa's staff.