

Features

- Operating voltage:2.4-5.2V
- Built-in 32kHz RC oscillator (default)
- External 32kHz requery source (OSCI)
- 1/4 BIAS
- 1/8 duty (8 COM)
- Built-in 32 × 8 bit display RAM
- Selection of buzzer frequencies 2kHz、 4kHz
- STANDBY mode (by Cmd LCD OFF,SYS DIS)
- 8 kinds of time base/WDT clock sources
- Time base or WDT overflow output (/IRQ pin)
- 3 or 4 wire serial interface
- Software configuration LCD parameters
- Data mode and command mode instructions
- Read/Write address auto increment
- VLCD pin for adjusting LCD operating voltage ($\leq VDD$)
- Package:
LQFP52(14.0mm x 14.0mm PP=1.0mm)

1 General Description

VK0256C is a RAM Mapping 32x8 LCD Driver , It can support LCD screens with a maximum of 256 pattern(32SEGx8COM).Only 3 or 4 lines are required to communication interface with the VK0256C, it is used to configure display parameters and transfer display data, and can also enter the standby mode through Power down command (by Cmd LCD OFF,SYS DIS) .

2 Pinouts and pin description

2.1 VK0256C LQFP52 Pin Assignment

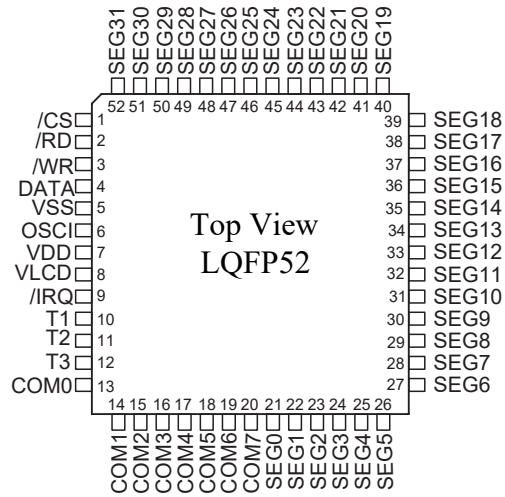

2.2 VK0256C LQFP52 Pin Description

No.	Name	I/O	Function
1	/CS	I	Chip selection input with pull-up resistor 1-disable, 0-enable.
2	/RD	I	READ clock input with pull-up resistor, data out on the falling edge of the /RD signal.
3	/WR	I	WRITE clock input with pull-up resistor, data latched on the rising edge of the /WR signal.
4	DATA	I/O	Serial data input/output with pull-high resistor.
5	VSS	VSS	Negative power supply
6	OSCI	I	External clock source: OSCI pin is connected to a, external clock source On-chip RC oscillator: the OSCI pin can be left open.
7	VDD	VDD	Positive power supply
8	VLCD	I	LCD power input
9	/IRQ	O	Time base or WDT overflow flag, NMOS open drain output.
10-12	T1-T3	—	---
13-20	COM0-COM7	O	LCD COM outputs
21-52	SEG0-SEG31	O	LCD SEG outputs

3 Functional Description

3.1 Block diagram

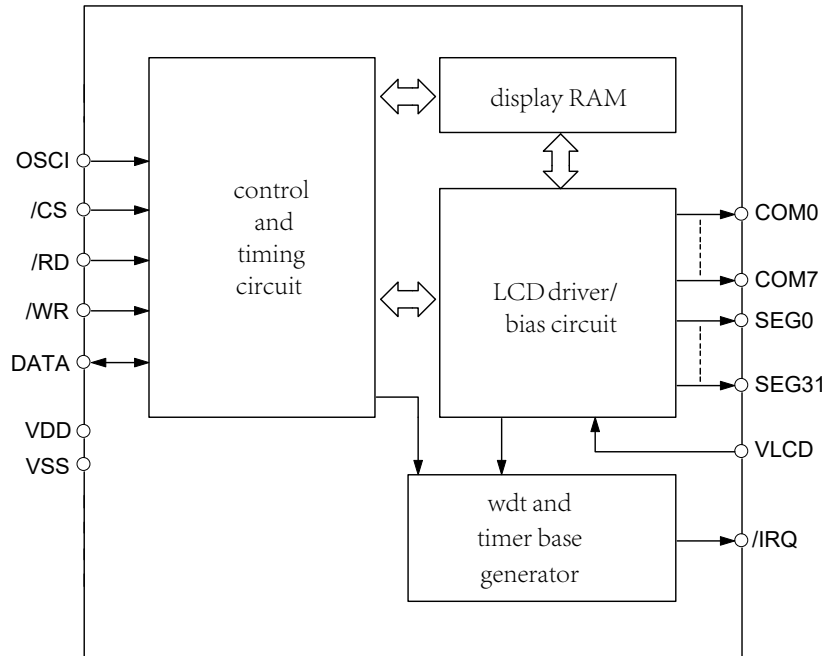

3.2 Display RAM

The static display memory (RAM) is organized into 32×8 bits and stores the displayed data. The contents of the RAM are directly mapped to the contents of the LCD driver. Data in the RAM can be accessed by the READ, WRITE, and READ-MODIFY-WRITE commands.

The following is a mapping from the RAM to the LCD pattern:

	COM7	COM6	COM5	COM4		COM3	COM2	COM1	COM0		
SEG0					1					0	address 6 bit (A5----A0)
SEG1					3					2	
SEG2					5					4	
SEG3					7					6	
⋮					⋮					⋮	
SEG31					63					62	
	D3	D2	D1	D0	Data\Addr	D3	D2	D1	D0	Data\Addr	

3.3 Time Base and WDT

The time base generator is comprised by an 8-stage count-up ripple counter and is designed to generate an accurate time base. The watch dog timer (WDT) is composed of an 8-stage time base generator along with a 2-stage count-up counter, it is designed to break the host controller from abnormal states such as unknown or unwanted jump, execution errors, etc. The WDT time-out will result in the setting of an internal WDT time-out flag. The outputs of the time base generator and of the WDT time-out flag can be connected to the /IRQ pin by a command option. There are totally 8 frequency sources available for the time base generator and the WDT clock. The frequency is calculated by the following equation.

$$f_{WDT} = f_{sys} / 2^n \quad (n=0\sim7) \quad f_{sys} = 32\text{kHz}$$

The time base generator and WDT share the same 8-stage counter. WDT is cleared by executing the CLR WDT command, time base generator is cleared by executing the CLR WDT or the CLR TIMER command.

Executing the WDT EN command not only enables the time base generator but activates the WDT time-out flag output (connect the WDT time-out flag to the /IRQ pin). Invoking the WDT DIS command disables the time base generator. After the TIMER EN command is transferred, the WDT is disconnected from the /IRQ pin, and the output of the time base generator is connected to the /IRQ pin.

The /IRQ output can be enabled or disabled by executing the IRQ EN or the IRQ DIS command. After the system power on, the /IRQ will be disabled.

Timer and WDT Configurations:

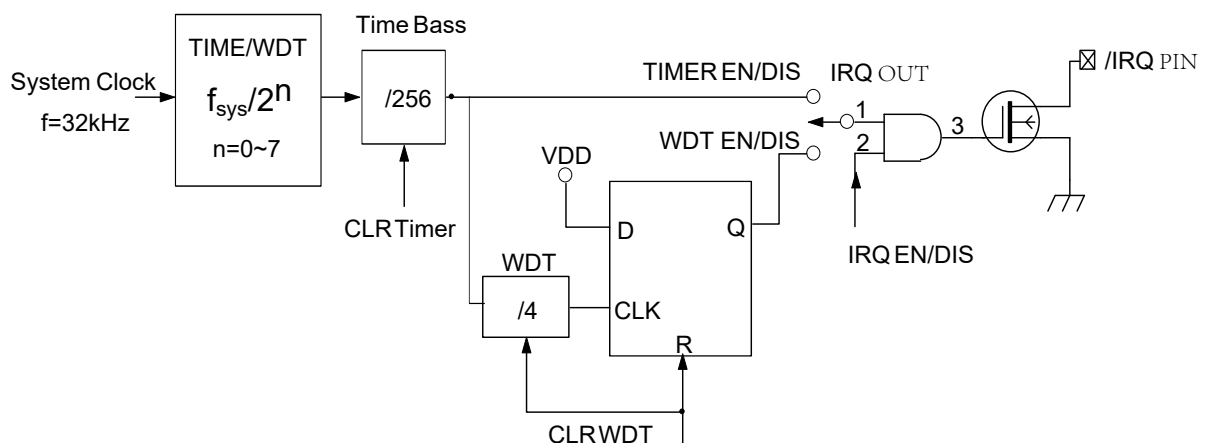

3.4 LCD Driver

The VK0256C is a 256 (32×8) pattern LCD driver, 1/4bias and 1/8duty (8 com).

3.4.1 Communication Interfacing

Four lines are required to interface with the VK0256C. If only used for display, only 3 pins can be used.

The /CS pin is used to initialize the serial interface circuit and to terminate the communication with HOST.

The DATA pin is the serial data input/output line. Data to be read or written or commands to be written have to be passed through the DATA line.

The /RD line is the READ clock input. Data in the RAM are clocked out on the falling edge of the /RD signal, and the clocked out data will then appear on the DATA line

The /WR line is the WRITE clock input. The data, address, and command on the DATA line are all clocked into the VK0256C on the rising edge of the WR signal.

The /IRQ pin can be selected as a timer output or a WDT overflow flag output by the software setting, it is a NMOS open drain output..

3.4.2 Command Format

VK0256C can be configured by the Software setting. There are two mode commands to configure the LCD parameters and to transfer the LCD display data, The configuration mode of the VK0256C is called command mode, and its command mode ID is 1 0 0. The data mode includes READ, WRITE, and READ-MODIFY-WRITE operations.

The following are the data mode IDs and the command mode ID:

Operation	MODE	ID
READ	DATA	110
WRITE	DATA	101
Read-Modify-Write	DATA	101
COMMAND	COMMAND	100

3.4.3 Cmd/Data Timing Diagram

The following are the data mode IDs and the command mode ID Timing Diagrams.

3.4.3.1 READ Mode

Command Code : 110

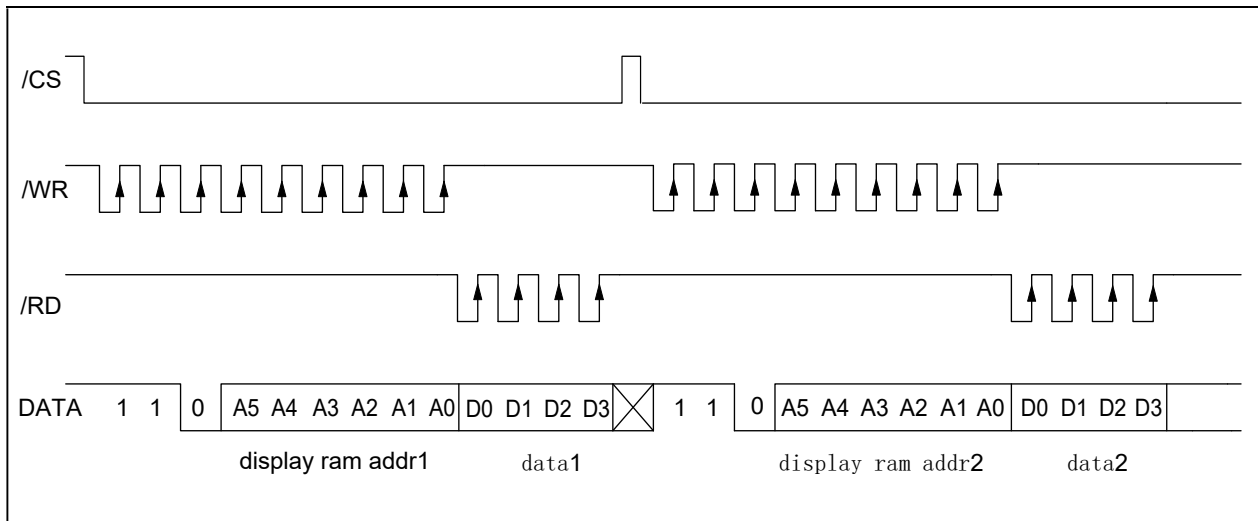

Successive Address Reading

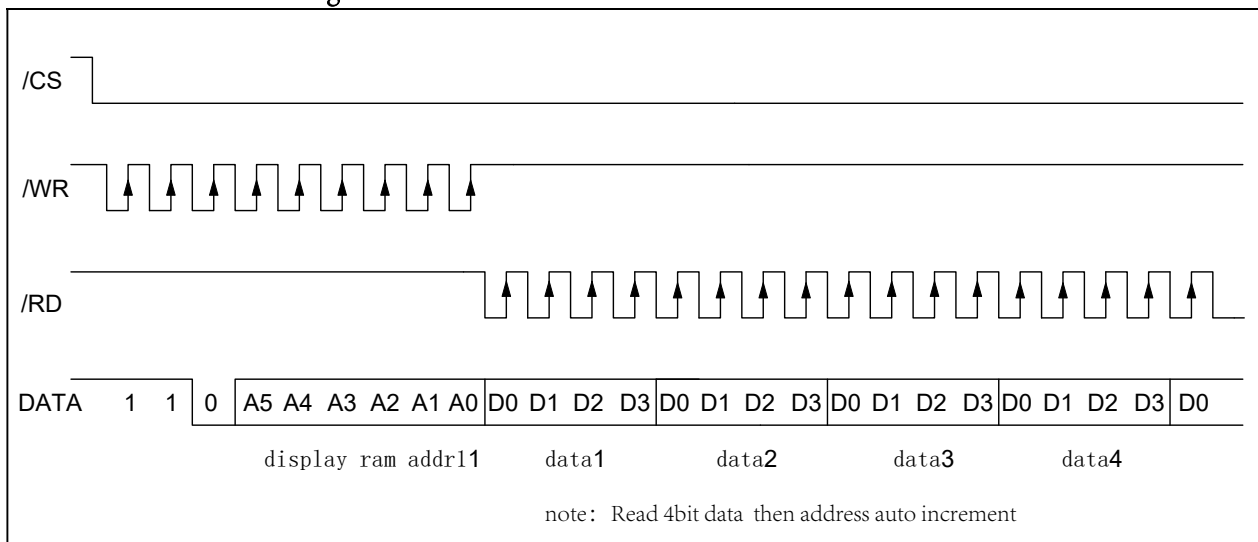

3.4.3.2 WRITE Mode

Command Code : 101

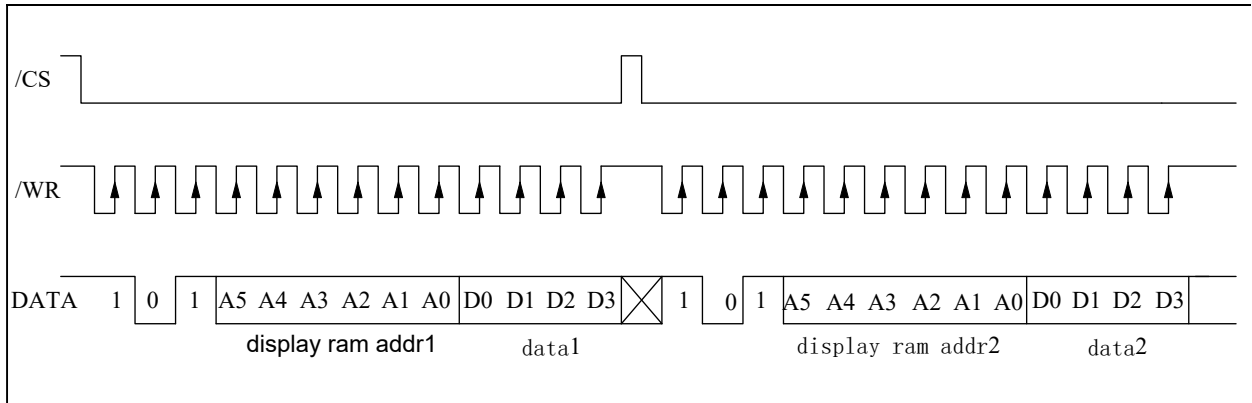

Successive Address Writing

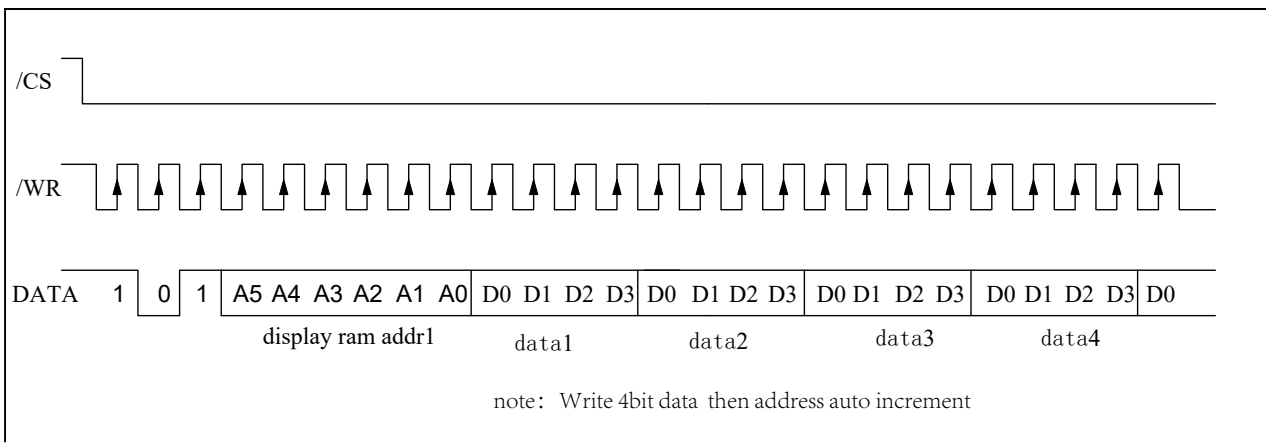

3.4.3.3 Read-Modify-Write Mode

Command Code : 101

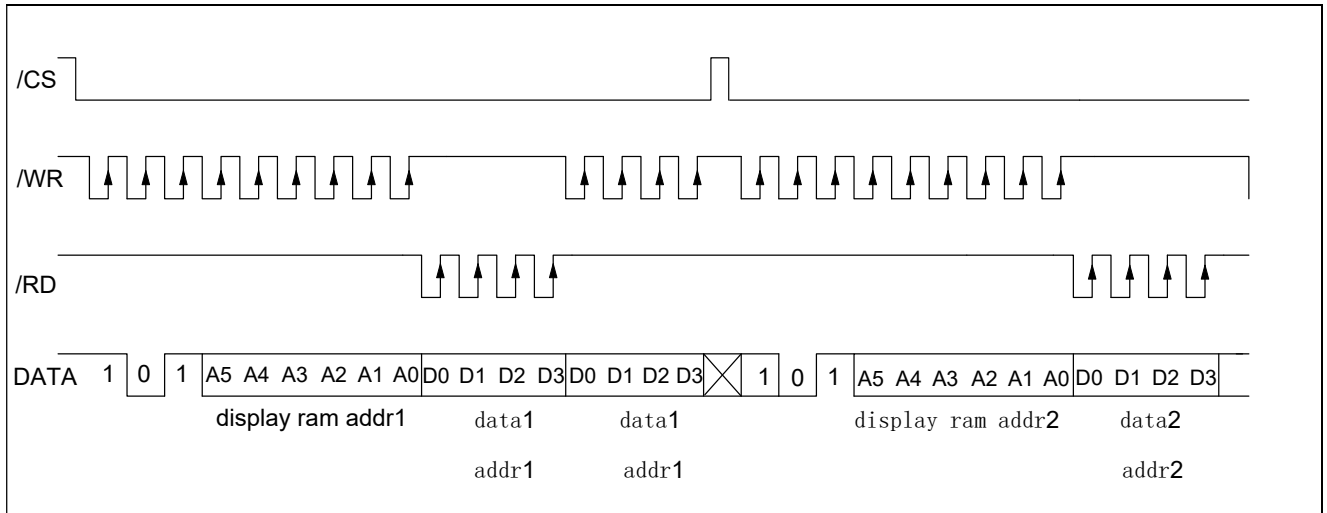

Successive Address Accessing

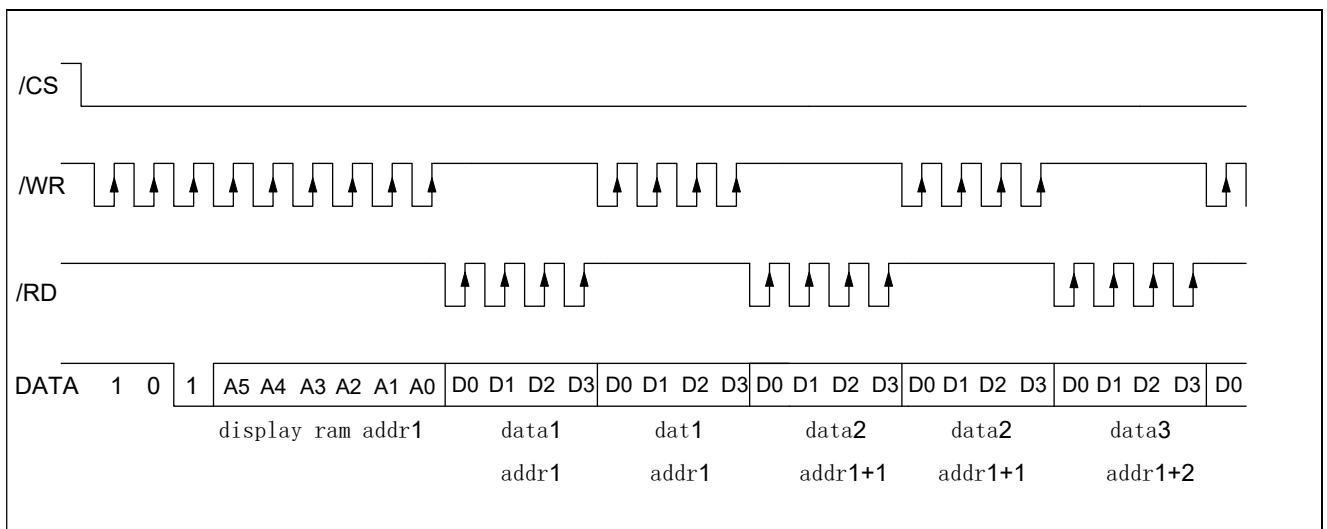

3.4.3.4 Command Mode

Command Code : 100

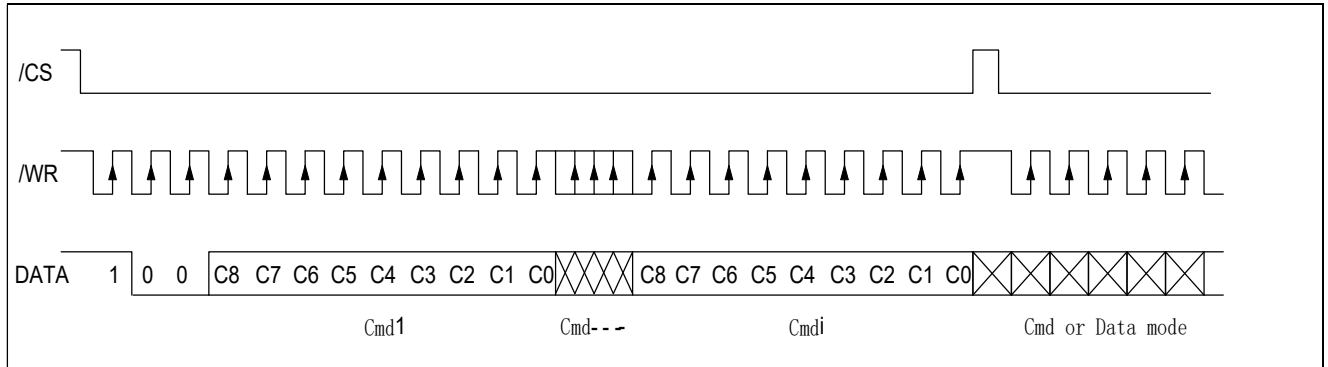

3.4.3.5 Data and Command Mode

Data and Command Mode

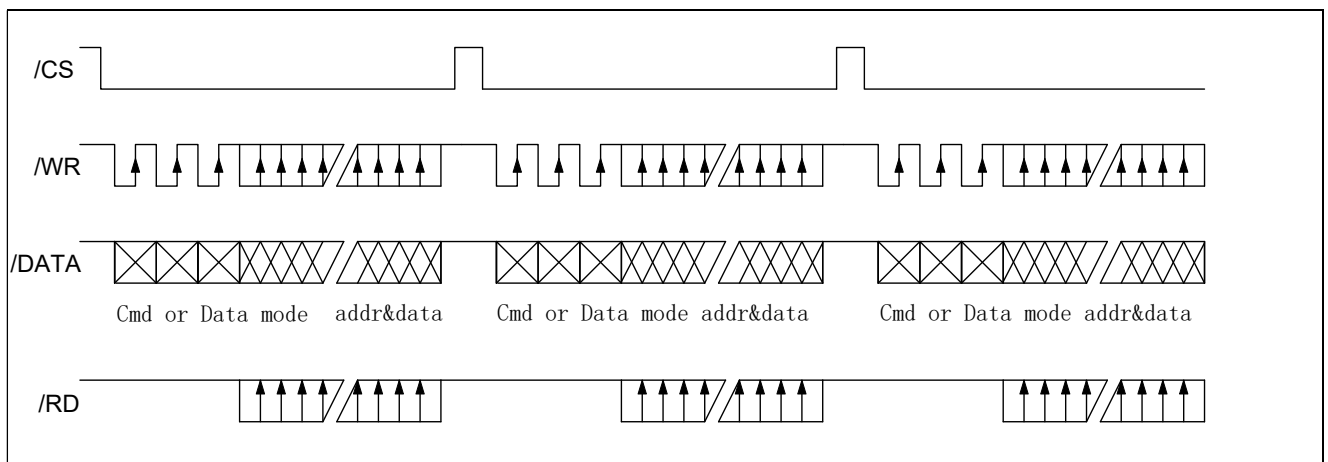

4 Command Summary

Name	ID	Command Code	D/C	Function	Def.
READ	110	A5A4A3A2A1A0D0D1D2D3	D	Read data from the RAM	
WRITE	101	A5A4A3A2A1A0D0D1D2D3	D	Write data to the RAM	
READ-MODIFY-WRITE	101	A5A4A3A2A1A0D0D1D2D3	D	READ and WRITE to the RAM	
SYS DIS	100	0000- 0000-X	C	Turn off system oscillator	YES
SYS EN	100	0000- 0001-X	C	Turn on system oscillator	
LCD OFF	100	0000- 0010-X	C	Turn off LCD bias generator	YES
LCD ON	100	0000- 0011-X	C	Turn on LCD bias generator	
TIMERS DIS	100	0000- 0100-X	C	Disable time base output	
WDT DIS	100	0000- 0101-X	C	Disable WDT time-out flag output	
TIMER EN	100	0000- 0110-X	C	Enable time base output	
WDT EN	100	0000- 0111-X	C	Enable WDT time-out flag output	
CLR TIMER	100	0000-11XX-X	C	Clear the contents of time base generator	
CLR WDT	100	0000-111X-X	C	Clear the contents of WDT stage	
RC 32k	100	0001-10XX-X	C	on-chip RC oscillator	YES
EXT 32k	100	0001-11XX-X	C	external clock source	
IRQ DIS	100	100X-0XXX-X	C	Disable IRQ output	YES
IRQ EN	100	100X-1XXX-X	C	Enable IRQ output	
F1	100	101X-X000-X	C	Time base/WDT clock output:1Hz The WDT time-out flag after: 4s	
F2	100	101X-X001-X	C	Time base/WDT clock output:2Hz The WDT time-out flag after: 2s	
F4	100	101X-X010-X	C	Time base/WDT clock output:4Hz The WDT time-out flag after: 1s	
F8	100	101X-X011-X	C	Time base/WDT clock output:8Hz The WDT time-out flag after: 1/2s	
F16	100	101X-X100-X	C	Time base/WDT clock output:16Hz The WDT time-out flag after: 1/4s	
F32	100	101X-X101-X	C	Time base/WDT clock output:32Hz The WDT time-out flag after: 1/8s	
F64	100	101X-X110-X	C	Time base/WDT clock output:64Hz The WDT time-out flag after: 1/16s	
F128	100	101X-X111-X	C	Time base/WDT clock output:128Hz The WDT time-out flag after: 1/32s	YES
TEST	100	1110-0000- X	C	Test mode	
NORMAL	100	1110-0011- X	C	Normal mode	YES

Note : X: 0 or 1

A5-A0: Display RAM addresses
 D3-D0:4bit Display RAM data

D/C:Data/Command mode

Def.:Power on reset default

110,101and 100 is Command ID

5 Application Circuits

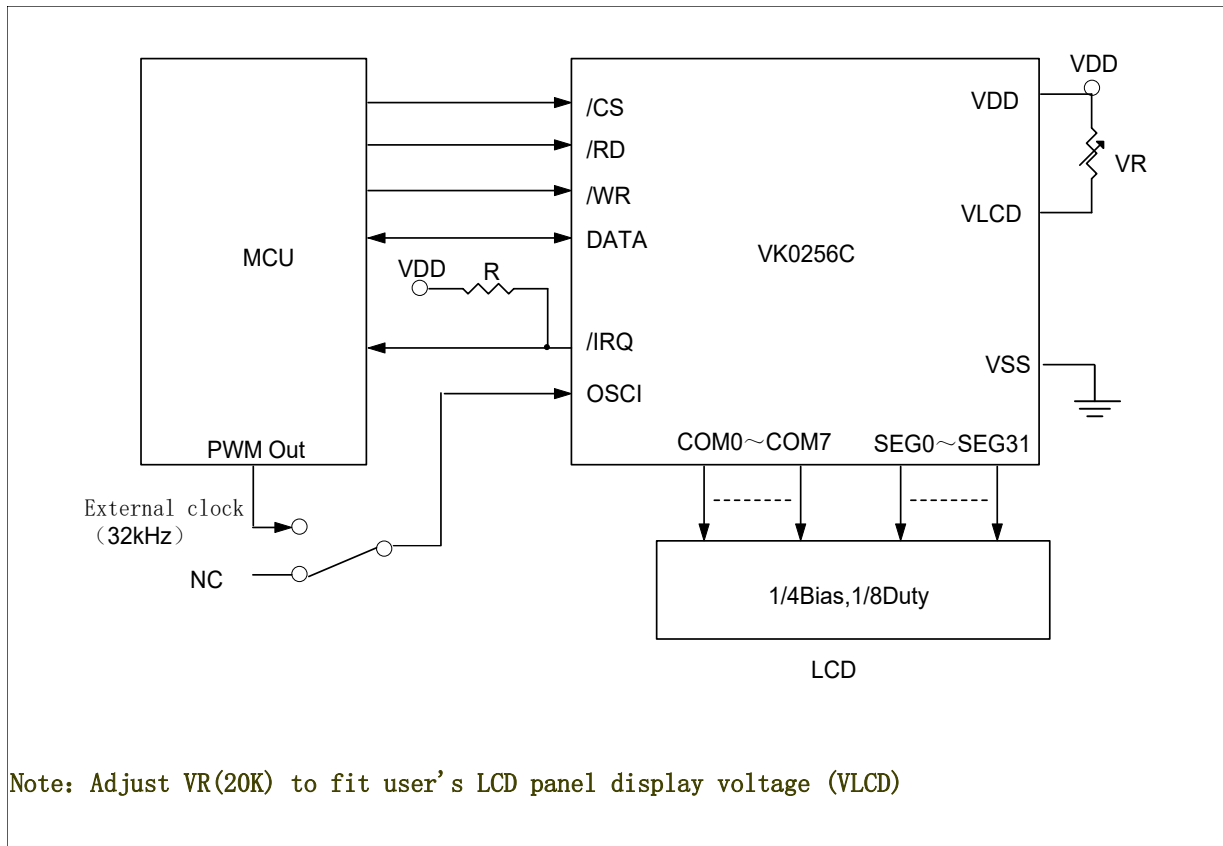

6 Electrical characteristics

6.1 Absolute Maximum Ratings

Item	Symbol	Ratings	Unit
Power voltage	VDD	-0.3~5.5	V
Input Voltage	VIN	VSS-0.3~VDD+0.3	V
Storage Temperature	TSTG	-50~+125	°C
Operating Temperature	TOTG	-40~+85	°C

6.2 DC Characteristics

Item	Symbol	Min.	Typ.	Max.	Unit	Test Conditions	
						VDD	Conditions
Operating voltage	VDD	2.4	—	5.2	V	—	—
Operating current	I _{DD1}	—	80	210	μA	3V	No load/LCD ON On-chip RC oscillator
		—	135	415		5V	
Operating current	I _{DD2}	—	8	30	μA	3V	No load/LCD OFF On-chip RC oscillator
		—	20	55		5V	
Standby Current	I _{STB}	—	1	8	μA	3V	No load, Power down mode
		—	2	16		5V	
Input Low Voltage	V _{IL}	0	—	0.6	V	3V	DATA, /WR, /CS, /RD
		0	—	1.0		5V	
Input High Voltage	V _{IH}	2.4	—	3.0	V	3V	DATA, /WR, /CS, /RD
		4.0	—	5.0		5V	
/IRQ	I _{OL1}	0.9	1.8	—	mA	3V	V _{OL} =0.3V
		1.7	3.0	—		5V	V _{OL} =0.5V
DATA	I _{OL1}	200	450	—	μA	3V	V _{OL} =0.3V
		250	500	—		5V	V _{OL} =0.5V
DATA	I _{OH1}	-200	-450	—	μA	3V	V _{OH} =2.7V
		-250	-500	—		5V	V _{OH} =4.5V
LCD COM Sink Current	I _{OL2}	15	40	—	μA	3V	V _{OL} =0.3V
		100	200	—		5V	V _{OL} =0.5V
LCD COM Source Current	I _{OH2}	-15	-30	—	μA	3V	V _{OH} =2.7V
		-45	-90	—		5V	V _{OH} =4.5V
LCD SEG Sink Current	I _{OL3}	15	30	—	μA	3V	V _{OL} =0.3V
		70	150	—		5V	V _{OL} =0.5V
LCD SEG Source Current	I _{OH3}	-6	-13	—	μA	3V	V _{OH} =2.7V
		-20	-40	—		5V	V _{OH} =4.5V
Pull-UP Resistor	R _{UP}	100	200	300	kΩ	3V	DATA, /WR, /CS, /RD
		50	100	150		5V	

6.3 AC Characteristics

Item	Symbol	Min.	Typ.	Max.	Unit	Test Conditions	
						VDD	Conditions
System Clock	f_{SYS1}	22	32	40	kHz	3V	On-chip RC oscillator
		24	32	40		5V	
System Clock	f_{SYS2}	—	32	—	kHz	3V	External clock source
		—	32	—		5V	
LCD Clock	f_{LCD1}	44	64	80	Hz	3V	On-chip RC oscillator
		48	64	80		5V	
	f_{LCD2}	—	64	—	Hz	3V	External clock source
		—	64	—		5V	
LCD Common Period	t_{COM}	—	n/f_{LCD}	—	sec	—	N: Number of COM
Serial Data Clock (/WR)	F_{CLK1}	—	—	150	kHz	3V	Duty cycle 50%
		—	—	300		5V	
Serial Data Clock (/RD)	F_{CLK2}	—	—	75	kHz	3V	Duty cycle 50%
		—	—	150		5V	
Serial Interface Reset PW	t_{CS}	—	250	—	ns	—	/CS
/WR, /RD Input Pulse Width	t_{CLK}	3.34	—	—	μs	3V	Write mode
		6.67	—	—			Read mode
		1.67	—	—	μs	5V	Write mode
		3.34	—	—			Read mode
Rise/Fall Time Serial Data Clock Width	t_r, t_f	—	120	—	ns	3V	—
		—	120	—		5V	
Setup Time for DATA to /WR, /RD Clock Width	t_{su}	—	120	—	ns	3V	—
		—	120	—		5V	
Hold Time for DATA to /WR, /RD Clock Width	t_h	—	120	—	ns	3V	—
		—	120	—		5V	
Setup Time for /CS to /WR, /RD Clock Width	t_{su1}	—	100	—	ns	3V	—
		—	100	—		5V	
Hold Time for /CS to /WR, /RD Clock Width	t_{h1}	—	100	—	ns	3V	—
		—	100	—		5V	

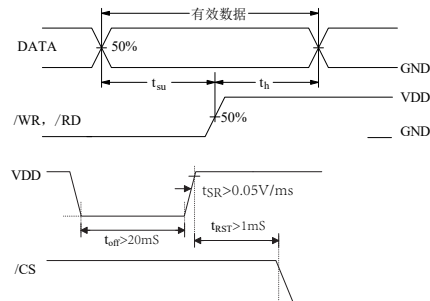
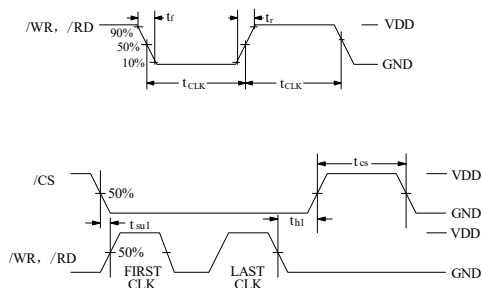

7 Package Information

7.1 LQFP52(14.0mm x 14.0mm PP=1.0mm):

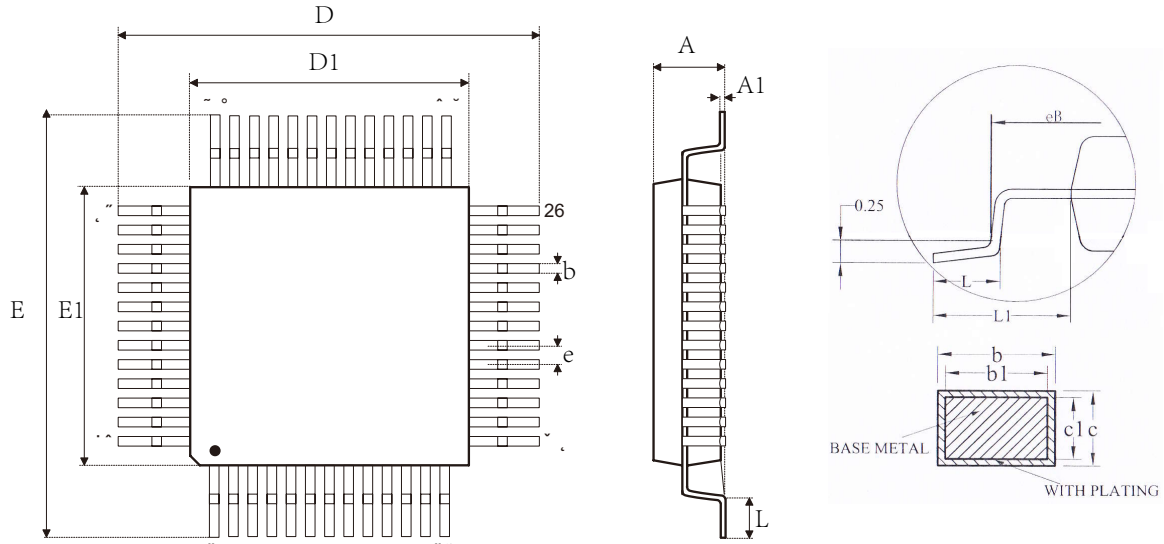

SYMBOL	MILLIMETER		
	MIN	NOM	MAX
A	--	--	1.60
A1	0.05	--	0.15
b	0.38	--	0.46
b1	0.37	0.40	0.43
c	0.13	--	0.17
c1	0.12	0.13	0.14
D	15.80	16.00	16.20
D1	13.90	14.00	14.10
E	15.80	16.00	16.20
E1	13.90	14.00	14.10
e	1.00BSC		
L	0.45	--	0.75
L1	1.00REF		

8 Revision history

No.	Version	Date	Modify the content	Check
1	1.0	2018-08-10	Original version	Yes
2	1.1	2018-10-11	Add Ref circuits	Yes
3	1.2	2019-03-21	Check para	Yes
4	1.3	2020-04-11	Update content	Yes

Disclaimers

Information in this document is believed to be accurate and reliable. However, VinKa does not give any representations or warranties, expressed or implied, as to the accuracy or completeness of such information. VinKa reserves the right to make changes to information published in this document, including without limitation specifications and product descriptions, at any time and without notice. This document supersedes and replaces all information supplied prior to the publication hereof. For the latest information, please visit <https://www.szvinka.com> Or contact VinKa's staff.