



# VK2C21B Datasheet

16×4/12×8 LCD DRIVER

Rev.1.3

## Intellectual Property Statement:

Shenzhen Vinka Microelectronics Co., Ltd. (hereinafter referred to as “the Company”) owns legally registered intellectual property rights in both domestic and international jurisdictions. Any unauthorized use of the Company’s products or patented technologies by individuals or organizations is strictly prohibited.

The Company reserves the right to take legal action against any infringement, and to seek full compensation for damages or unlawful gains.

The Company’s name and trademarks are legally protected and may not be used or imitated without explicit written permission. No implied or express license shall be granted under any circumstances.

## 1 General Description

The VK2C21B is a dot-matrix memory-mapped LCD driver that supports LCD screens with a maximum of 64 dots (16SEG×4COM) or 96 dots (12SEG×8COM). The single-chip microcomputer can configure display parameters and read and write display data through the I2C interface, and can also enter power-saving mode through instructions. Its high anti-interference and low power consumption features make it suitable for water, electricity and gas meters as well as various industrial control instruments.

## 2 Key Features

- Operating voltage: 2.4-5.5V
- Built-in RC oscillator (default)
- Selectable LCD bias: 1/3 or 1/4
- Selectable LCD duty: 1/4 or 1/8
- Built-in 20×4-bit、16×8-bit display RAM
- The frame rate can be configured as 80Hz or 160Hz
- Power-down mode via software command(LCD OFF, SYS DIS)
- I2C communication interface
- Display mode 16×4、12×8
- Three display overall flicker frequencies
- Software-configurable of LCD parameters
- Auto-increment addressing for sequential read/write
- VLCD pin provides the LCD driving voltage source(2.4-5.5V)
- It is equipped with a built-in 16-stage LCD driver voltage adjustment circuit
- Built-in power-on reset circuit (POR)
- Low power consumption and high anti-interference
- Available Packages:  
SOP24 (300mil) (15.4mm × 7.5mm PP=1.27mm)

### 3 Product Selection

Part No.	SEG × COM	BIAS	DUTY	Packaging
VK2C21A	20×4,16×8	1/3,1/4	1/4,1/8	SOP28
VK2C21AA	20×4,16×8	1/3,1/4	1/4,1/8	SSOP28
VK2C21AQ	20×4,16×8	1/3,1/4	1/4,1/8	QFN28L
VK2C21B	16×4,12×8	1/3,1/4	1/4,1/8	SOP24
VK2C21BA	16×4,12×8	1/3,1/4	1/4,1/8	SSOP24
VK2C21BQ	16×4,12×8	1/3,1/4	1/4,1/8	QFN24L
VK2C21C	12×4,8×8	1/3,1/4	1/4,1/8	SOP20
VK2C21CQ	12×4,8×8	1/3,1/4	1/4,1/8	QFN20L
VK2C21D	8×4,4×8	1/3,1/4	1/4,1/8	SOP16
VK2C21DQ	8×4,4×8	1/3,1/4	1/4,1/8	QFN16L

### 4 Ordering Information

Part No.	Packaging	Tube Qty	Tray Qty	Box Qty	Total Qty	Notes
VK2C21A	SOP28	26/tube		2080/box	20800 PCS	
VK2C21AA	SSOP28	50/tube		5000/box	50000 PCS	
VK2C21AQ	QFN28L		490/tray	4900/box	29400 PCS	
VK2C21B	SOP24	30/tube		2400/box	24000 PCS	
VK2C21BA	SSOP24	50/tube		10000/box	100000 PCS	
VK2C21BQ	QFN24L		490/tray	4900/box	29400 PCS	
VK2C21C	SOP20	36/tube		2880/box	28800 PCS	
VK2C21CQ	QFN20L		490/tray	4900/box	29400 PCS	
VK2C21D	SOP16	50/tube		10000/box	100000 PCS	
VK2C21DQ	QFN16L		3000/tray	3000/box	120000 PCS	

## 5 COB Pad Information

### 5.1 COB Pad Assignment

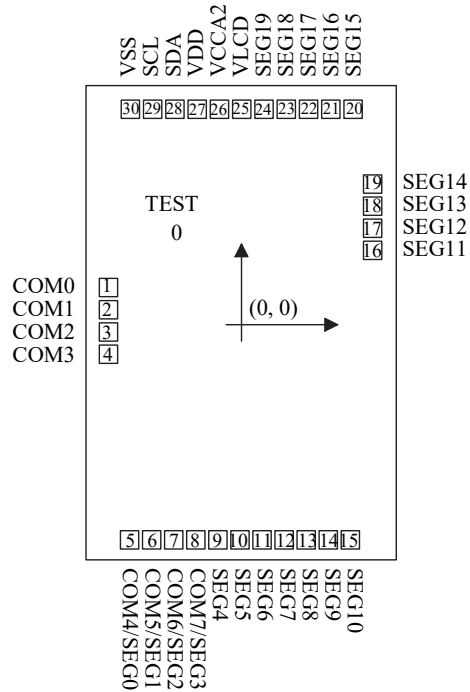

Chip size: 1150×1715 um<sup>2</sup>, substrate potential: VSS

PAD size: 70×70 um

VDD (Pad27) and VCCA2 (Pad26) must be bound together.

The VLCD (Pad25) and SEG19 (Pad24) must be bound together.

When the VLCD pins are configured to detect the internal bias voltage, the LCD drive voltage can be externally temperature-compensated through the voltage provided by the VLCD pins.

## 5.2 COB PAD Coordinates

Unit: um

Pad No	Name	X	Y	Pad No	Name	X	Y
1	COM0	93.11	1016.655	17	SEG12	1056.89	1621.89
2	COM1	93.11	932.155	18	SEG13	1056.89	1265.89
3	COM2	93.11	847.655	19	SEG14	1056.89	1350.39
4	COM3	93.11	763.155	20	SEG15	1040.39	1621.89
5	COM4/SEG0	130.97	93.11	21	SEG16	950.39	1621.89
6	COM5/SEG1	220.97	93.11	22	SEG17	860.39	1621.89
7	COM6/SEG2	310.9	93.11	23	SEG18	756.75	1621.89
8	COM7/SEG3	400.97	93.11	24	SEG19	666.75	1621.89
9	SEG4	490.97	93.11	25	VLCD	576.75	1621.89
10	SEG5	580.97	93.11	26	VCCA2	486.75	1621.89
11	SEG6	670.97	93.11	27	VDD	396.75	1621.89
12	SEG7	760.97	93.11	28	SDA	306.75	1621.89
13	SEG8	850.97	93.11	29	SCL	199.61	1621.89
14	SEG9	940.97	93.11	30	VSS	109.61	1621.89
15	SEG10	1030.97	93.11				
16	SEG11	1056.89	1096.89	0	TEST	295.57	1211.795

## 6 Package Pinout Information(SOP24)

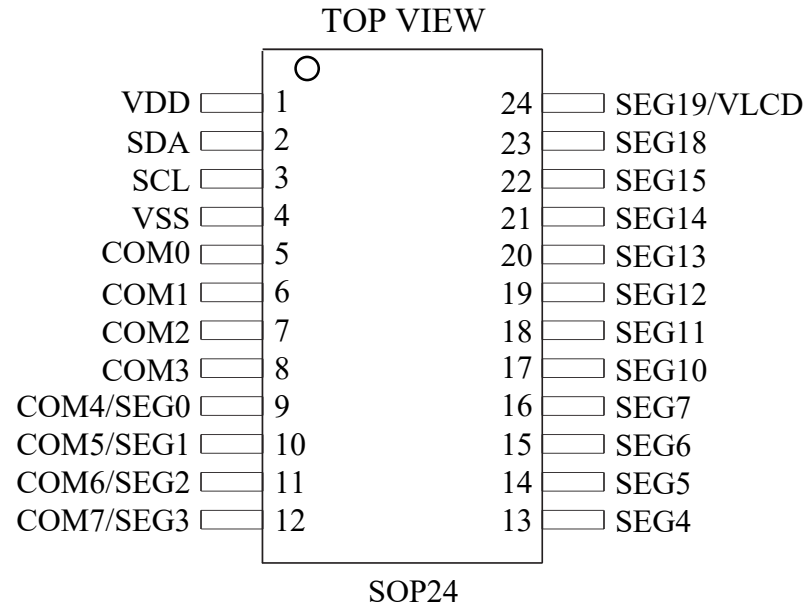

For more information: [Page 21](#)

## 6.1 VK2C21B/SOP24 Pin Description

No.	Name	I/O	Function
1	VDD	VDD	Positive power supply
2	SDA	I/O	Serial Data Input/Output for I2C interface
3	SCL	I	Serial Clock Input for I2C interface
4	VSS	VSS	Negative power supply
5-8	COM0-COM3	O	LCD COM drive outputs
9-12	COM4/SEG0-COM7/SEG3	O	LCD SEG/COM drive outputs, software configuration 4COM or 8COM
13-16	SEG4-SEG7	O	LCD SEG drive outputs
17-22	SEG10-SEG15	O	LCD SEG drive outputs
23	SEG18	O	LCD SEG drive outputs
24	SEG19/VLCD	I/O	<p>When the VLCD pin and VDD pin are short-circuited and the internal voltage regulation function is enabled, the drive voltage is regulated by the internal voltage regulation function.</p> <p>When the VLCD pin is connected in series with the VDD pin and the internal voltage adjustment function is disabled, the LCD driving voltage is set by the series resistor.</p>

## 7 Functional Description

### 7.1 Block Diagram

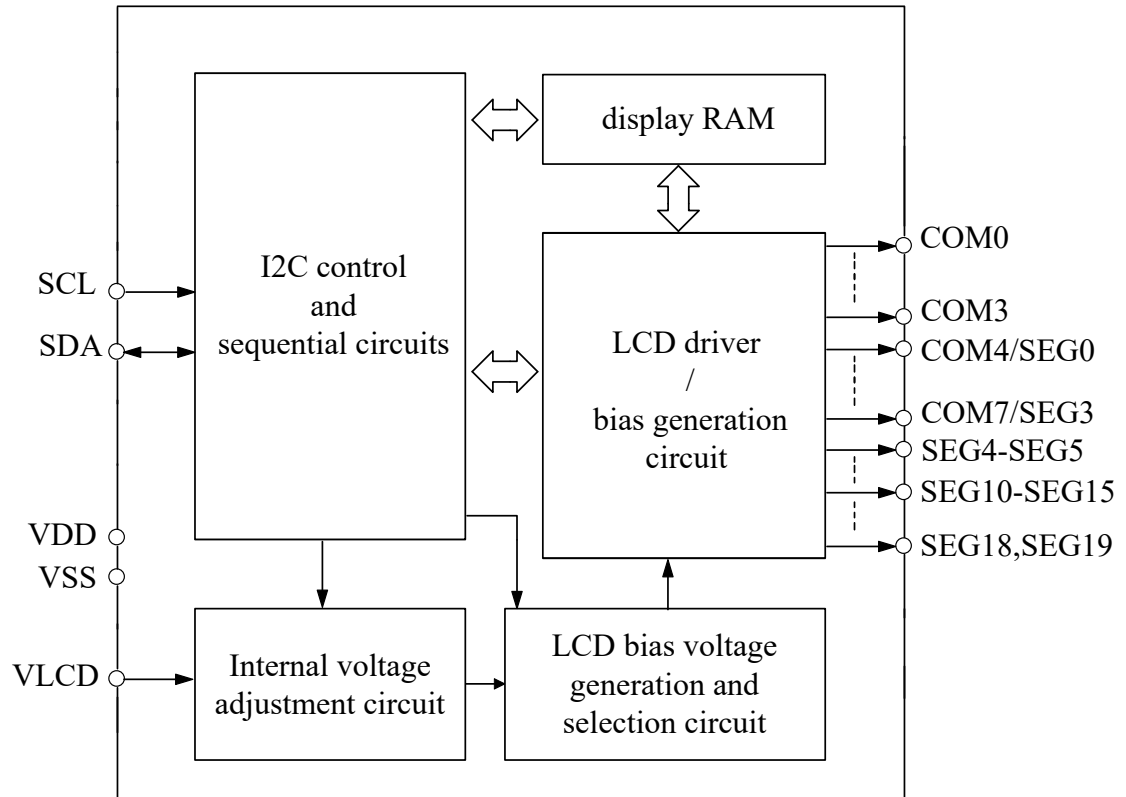

## 7.2 Display RAM

The display RAM is organized as 16×8 bits (or 20×4 bits for 4-COM mode), which stores the displayed data. The content of the display RAM is directly mapped to the display content of the LCD driver. Display RAM data is accessed via I2C commands.

The following is a mapping from the RAM to the LCD pattern:

Output	COM3	COM2	COM1	COM0	Output	COM3	COM2	COM1	COM0	Address
SEG1					SEG0					0x00
SEG3					SEG2					0x01
SEG5					SEG4					0x02
SEG7					SEG6					0x03
---					---					0x04
SEG11					SEG10					0x05
SEG13					SEG12					0x06
SEG15					SEG14					0x07
----					---					0x08
SEG19					SEG18					0x09
Data	Bit7	Bit6	Bit5	Bit4		Bit3	Bit2	Bit1	Bit0	

RAM Mapping of 20×4

Output	COM7/ SEG3	COM6/ SEG2	COM5/ SEG1	COM4/ SEG0	COM3	COM2	COM1	COM0	Address
SEG4									0x00
SEG5									0x01
SEG6									0x02
SEG7									0x03
---									0x04
---									0x05
SEG10									0x06
SEG11									0x07
SEG12									0x08
SEG13									0x09
SEG14									0x0A
SEG15									0x0B
---									0x0C
---									0x0D
SEG18									0x0E
SEG19									0x0F
Data	Bit7	Bit6	Bit5	Bit4	Bit3	Bit2	Bit1	Bit0	

RAM Mapping of 16×8

### 7.3 System Oscillator

The clock of VK2C21B is used to generate LCD drive signals and internal logic timing. The system clock is derived from the internal RC oscillator (32kHz), and the system clock frequency ( $f_{SYS}$ ) determines the LCD frame frequency.

The system setting command can start or stop the system oscillator. After the display shows off and the system oscillator stops, the system enters the power-saving mode.

When the system is powered on and working, the system oscillator is in a stopped state.

The Settings of the system oscillation are shown in the following figure:

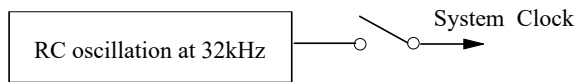

### 7.4 LCD operating voltage

The LCD driving voltage can be obtained through the VLCD pins or by selecting 16 levels of voltage through the internal configuration.

When the VDD pad is connected to the VCCA2 pad, the LCD driving voltage can be obtained by connecting the VLCD pin to VDD through a series resistor ( $VLCD \leq VDD$ ).

The internal 16-level voltage is set through a 4-bit programmable analog switch, as shown in the following table:

DA3~DA0 \ Bias	1/3	1/4	Note
0x00	1.000×VDD	1.000×VDD	Default
0x01	0.944×VDD	0.957×VDD	
0x02	0.894×VDD	0.918×VDD	
0x03	0.849×VDD	0.882×VDD	
0x04	0.808×VDD	0.849×VDD	
0x05	0.771×VDD	0.818×VDD	
0x06	0.738×VDD	0.789×VDD	
0x07	0.707×VDD	0.763×VDD	
0x08	0.678×VDD	0.738×VDD	
0x09	0.652×VDD	0.714×VDD	
0x0A	0.628×VDD	0.692×VDD	
0x0B	0.605×VDD	0.672×VDD	
0x0C	0.584×VDD	0.652×VDD	
0x0D	0.565×VDD	0.634×VDD	
0x0E	0.547×VDD	0.616×VDD	
0x0F	0.529×VDD	0.600×VDD	

## 7.5 Power-On Reset

During the initialization of the power-on reset circuit(1ms),no I2C data transmission should occur.

The state of the internal circuit after initialization is as follows:

- When  $VDD \leq VLCD$ , all COM/SEG pins output VLCD.
- Display modes 1/4 duty and 1/3 bias.
- The system oscillator and LCD bias generator are turned off.
- LCD display off.
- The internal voltage adjustment function is enabled.
- The SEG/VLCD shared pin is set as the SEG pin.
- The VLCD foot detection function is disabled.
- The frame rate is set to 80Hz by default.
- The flashing function is disabled.

If,during operation, VDD falls below the specified minimum operating voltage, the power-on reset timing requirements must be met, that is, the VDD voltage must drop to 0V and remain at 0V for at least 20ms before rising to the normal operating voltage

Power-on Reset Timing:

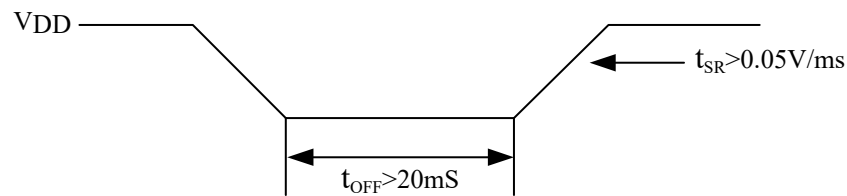

## 7.6 LCD Communication Command

The LCD driver supports 16SEG×4COM and 12SEG×8COM modes, any unused SEG and COM pins should be left floating(NC).

Two frame rates are provided. You can choose between 80Hz and 160Hz through the frame rate setting command.

## 8 I2C Serial Interface

The VK2C21B features two communication pins compliant with the I2C protocol. open-drain outputs require external pull-up resistors.

The SCL pin is the clock input pin, and the SDA pin is the serial data input/output pin. When the I2C bus is idle, both pins remain at a logic high level.

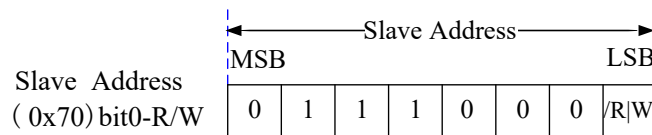
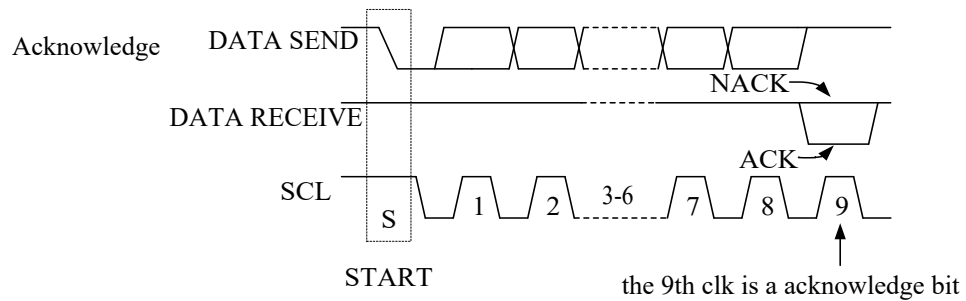
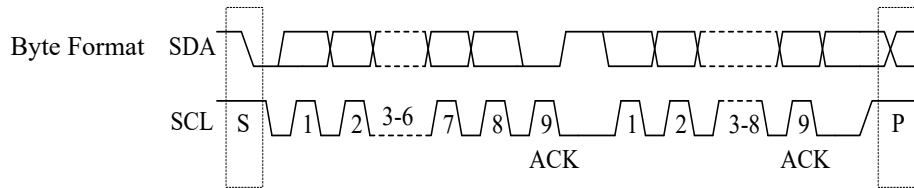
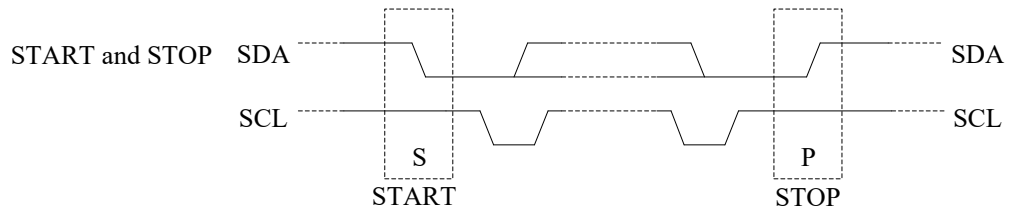

## 9 I2C Command Format

Write operation

Write commands

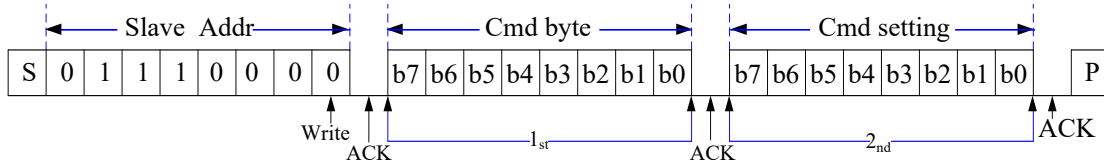

Write a single byte to the display RAM

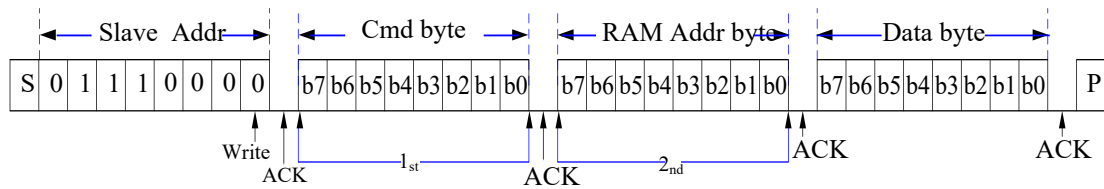

Write multiple bytes to the display RAM

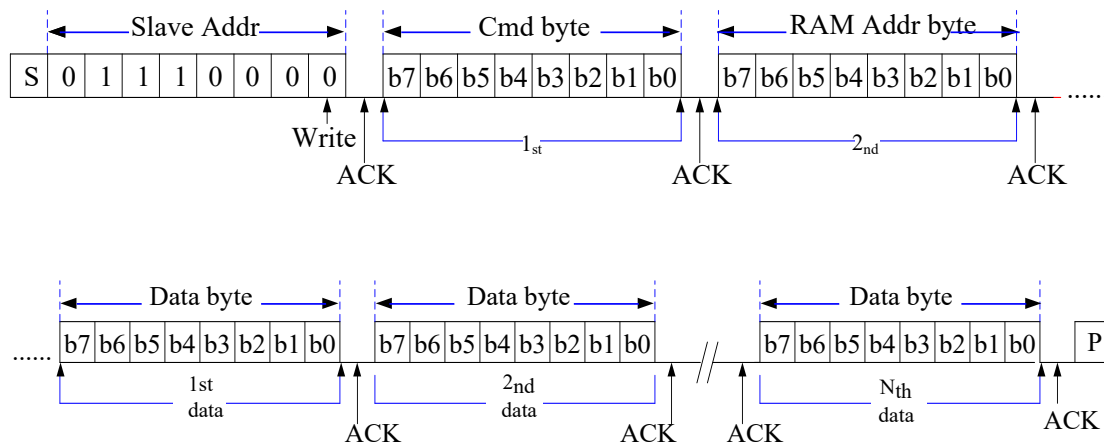

## Read Operation

Read multiple bytes from the display RAM

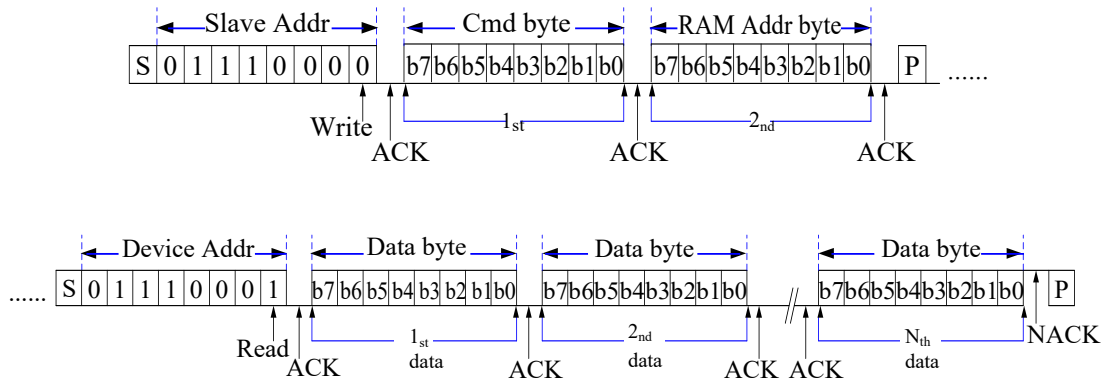

## 10 Command Summary

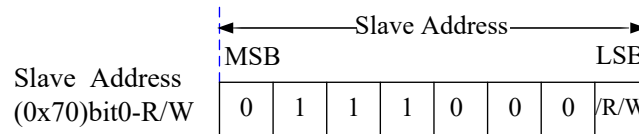

### 10.1 Display Data Command

Send display data to display RAM

Function	Byte	Bit 7	Bit 6	Bit 5	Bit 4	Bit 3	Bit 2	Bit 1	Bit 0	Note	R/W	Def
Display data command	1st	1	0	0	0	0	0	0	0		W	
Address pointer	2nd	X	X	A5	A4	A3	A2	A1	A0	Display data start address	W	00H

## 10.2 Mode Set Command

Set BIAS and DUTY

Function	Byte	Bit 7	Bit 6	Bit 5	Bit 4	Bit 3	Bit 2	Bit 1	Bit 0	Note	R/W	Def
mode set cmd	1st	1	0	0	0	0	0	1	0		W	
Duty and Bias	2nd	X	X	X	X	X	X	Duty	Bias		W	00H

Bit 1	Bit 0	Duty	Bias
Duty	Bias		
0	0	1/4 duty	1/3 bias
0	1	1/4 duty	1/4 bias
1	0	1/8 duty	1/3 bias
1	1	1/8 duty	1/4 bias

## 10.3 System Set Command

Enable/disable the internal system oscillator and LCD display

Function	Byte	Bit 7	Bit 6	Bit 5	Bit 4	Bit 3	Bit 2	Bit 1	Bit 0	Note	R/W	Def
system set cmd	1st	1	0	0	0	0	1	0	0		W	
System oscillator and Display on/off set	2nd	X	X	X	X	X	X	S	E		W	00H

Bit 1	Bit 0	internal oscillator	LCD on/off
S	E		
0	X	off	off
1	0	on	off
1	1	on	on

## 10.4 Frame Frequency Command

Selects the frame frequency

Function	Byte	Bit 7	Bit 6	Bit 5	Bit 4	Bit 3	Bit 2	Bit 1	Bit 0	Note	R/W	Def
frame freq cmd	1st	1	0	0	0	0	1	1	0		W	
frame freq set	2nd	X	X	X	X	X	X	X	F		W	00H

Bit 0	Frame Frequency
F	
0	80Hz
1	160Hz

## 10.5 Blinking Frequency Command

Set the blinking frequency

Function	Byte	Bit 7	Bit 6	Bit 5	Bit 4	Bit 3	Bit 2	Bit 1	Bit 0	Note	R/W	Def
blinking freq cmd	1st	1	0	0	0	1	0	0	0		W	
blinking freq set	2nd	X	X	X	X	X	X	BK1	BK0		W	00H

Bit 1	Bit 0	blinking freq
BK1	BK0	
0	0	blinking off(Def)
0	1	2Hz
1	0	1Hz
1	1	0.5Hz

## 10.6 Internal Voltage Adjustment(IVA) Command

The IVA command allows selection of 16 voltage levels to adjust the LCD driver voltage

Function	Byte	Bit 7	Bit 6	Bit 5	Bit 4	Bit 3	Bit 2	Bit 1	Bit 0	Note	R/W	Def
IVA cmd	1 <sup>st</sup>	1	0	0	0	1	0	1	0		W	
IVA set	2 <sup>nd</sup>	X	X	DE	VE	DA3	DA2	DA1	DA0	SEG/VLCD pin can be set via the DE bit. internal voltage adjustment can be set via the VE bit. DA3~DA0 bits can be used to adjust the VLCD output voltage.	W	30H

Note:

Bit 5	Bit 4	SEG19/VLCD shared pin sel	internal voltage adjustment	Note
DE	VE			
0	0	VLCD pin	off	<ul style="list-style-type: none"> <li>SEG/VLCD pin is set as the VLCD pin</li> <li>Disable internal voltage adjustment function</li> <li>An external resistor is connected in series between the VLCD pin and the VDD pin to adjust the bias voltage. At the same time, the DA3-DA0 bit must be set to a value other than "0000" to enable the internal voltage follower.</li> <li>VLCD pin is connected to the VDD pin, the internal voltage must be disabled by set DA3~DA0 as "0000".</li> </ul>
0	1	VLCD pin	on	<ul style="list-style-type: none"> <li>SEG/VLCD pin is set as the VLCD pin</li> <li>Enable internal voltage adjustment function</li> <li>The VLCD pin is an output pin, and the voltage of the VLCD pin is detected by the MCU.</li> </ul>
1	0	SEG19 pin	off	<ul style="list-style-type: none"> <li>SEG/VLCD pin is set as the segment pin</li> <li>Disable internal voltage adjustment function.</li> <li>The bias voltage is provided by internal VDD.</li> <li>Regardless of the value of DA3-DA0, the internal voltage follower is prohibited.</li> </ul>
1	1	SEG19 pin	on	<ul style="list-style-type: none"> <li>SEG/VLCD pin is set as the segment pin</li> <li>Enable internal voltage adjustment function</li> </ul>

- Power-on: Enable internal voltage Adjustment and the SEG/VLCD pin is set as the segment pin.
- When the DA0~DA3 bits are set to "0000", the internal voltage is disabled.
- When the DA0~DA3 bits are set to other values except "0000", internal voltage follower is enabled.

## 11 Application Circuits

When the surrounding interference is relatively large, a 10R to 1k resistor and a PF-level small capacitor to ground can be connected in series on the communication pin

When the power supply of the single-chip microcomputer (3.3V) and the driver chip (5V) is inconsistent, it is recommended to add a level conversion circuit to the communication pin

VDD=2.4V-5.5V

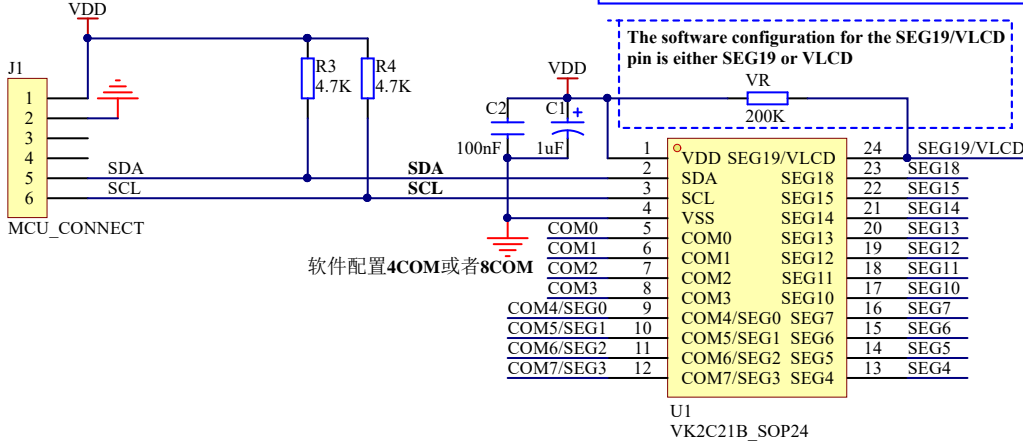

The software configuration of SEG19/VLCD pins is VLCD  
When VDD=5V and VR=200K:  
The VLCD is approximately 4.2V  
It is recommended to use a 510K adjustable resistor for VR to adjust it to the best display effect and take the resistance value at this time.

The software configuration for the SEG19/VLCD pin is either SEG19 or VLCD

The software is configured as 8COM

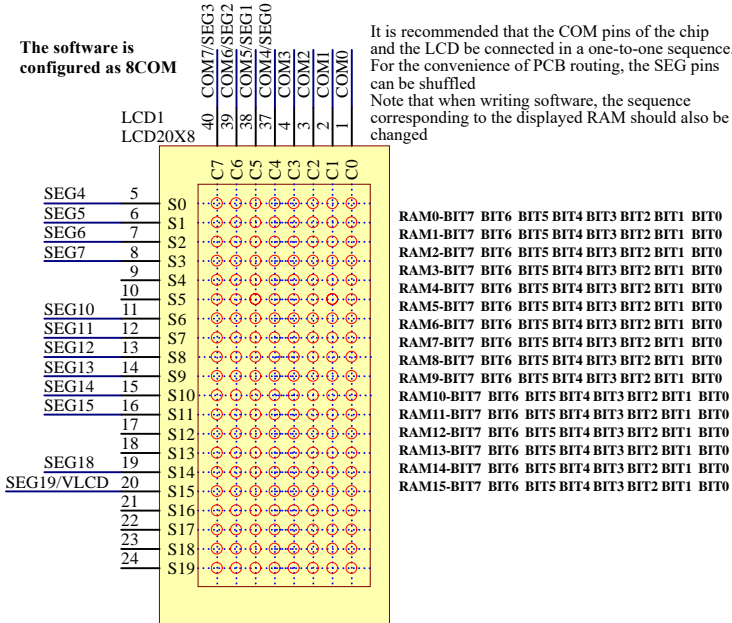

The software is configured as 4COM

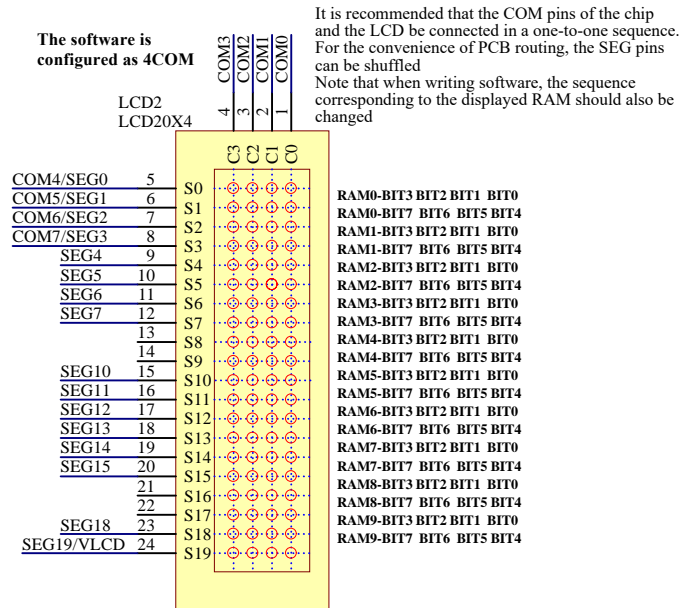

## 12 Electrical Characteristics

### 12.1 Absolute Maximum Ratings

Parameter	Symbol	Ratings	Unit
Supply voltage	VDD	-0.3~6.5	V
Input Voltage	VIN	VSS-0.3~VDD+0.3	V
Storage Temperature	T <sub>STG</sub>	-50~+125	°C
Operating Temperature	T <sub>OTG</sub>	-40~+85	°C

### 12.2 DC Electrical Characteristics

Parameter	Symbol	Min.	Typ.	Max.	Unit	Test Conditions	
						VDD	Conditions
Operating voltage	VDD	2.4	—	5.5	V	—	—
Operating current	IDD1	—	18	27	μA	3V	No load, VLCD=VDD, 1/3 bias, fLCD=80Hz, LCD off, Internal osc on, DA0~DA3 = "0000"
		—	25	40		5V	
Operating current	IDD2	—	2	5	μA	3V	No load, VLCD=VDD, 1/3 bias, fLCD=80Hz, LCD off, Internal osc on, DA0~DA3 = "0000"
		—	4	10		5V	
Standby Current	ISTB	—	0.1	1	μA	3V	No load, VLCD=VDD, LCD off, Internal osc off
		—	0.3	2		5V	
Low-level Input	VIL	0	—	0.3	VDD	3V	SCL, SDA
						5V	
High-level Input	VIH	0.7	—	1.0	VDD	3V	SCL, SDA
						5V	
Low Level Output Current	IOL	3.0	—	—	mA	3V	VOL=0.4V, SDA
		6.0	—	—		5V	
LCD COM Sink Current	IOL1	250	400	—	μA	3V	VOL=0.3V
		500	800	—		5V	VOL=0.5V
LCD COM Source Current	IOH1	-140	-230	—	μA	3V	VOH=2.7V
		-300	-500	—		5V	VOH=4.5V
LCD SEG Sink Current	IOL2	250	400	—	μA	3V	VOL=0.3V
		500	800	—		5V	VOL=0.5V
LCD SEG Source Current	IOH2	-140	-230	—	μA	3V	VOH=2.7V
		-300	-500	—		5V	VOH=4.5V

## 13 AC Electrical Characteristics

### Frame Frequency

Parameter	Symbol	Min.	Typ.	Max.	Unit	Test Conditions	
						VDD	Conditions
LCD Frame Frequency	f <sub>LCD1</sub>	72	80	88	Hz	4.0V	1/4 duty, 25°C
LCD Frame Frequency	f <sub>LCD2</sub>	144	160	176	Hz	4.0V	1/4 duty, 25°C
LCD Frame Frequency	f <sub>LCD3</sub>	52	80	124	Hz	4.0V	1/4 duty, -40 ~ +85°C
LCD Frame Frequency	f <sub>LCD4</sub>	104	160	248	Hz	4.0V	1/4 duty, -40 ~ +85°C

### I2C parameter

Parameter	Symbol	Min.	Typ.	Max.	Unit	Test Conditions	
						VDD	Conditions
Clock Frequency	f <sub>SCL</sub>	—	—	400	kHz	3.0-5.5V	—
Bus Free Time	t <sub>BUF</sub>	1.3	—	—	μs	3.0-5.5V	Time in which the bus must be free before a new transmission can start
Start Condition Hold Time	t <sub>HD:STA</sub>	0.6	—	—	μs	3.0-5.5V	After this period, the first clock pulse is generated
SCL Low Time	t <sub>LOW</sub>	1.3	—	—	μs	3.0-5.5V	—
SCL High Time	t <sub>HIGH</sub>	0.6	—	—	μs	3.0-5.5V	—
Start Condition Setup Time	t <sub>SU:STA</sub>	0.6	—	—	μs	3.0-5.5V	Only relevant for repeated START condition
Data Hold Time	t <sub>HD:DAT</sub>	0	—	—	ns	3.0-5.5V	—
Data Setup Time	t <sub>SU:DAT</sub>	100	—	—	ns	3.0-5.5V	—
SDA and SCL Rising Time	t <sub>R</sub>	—	—	0.3	μs	3.0-5.5V	periodically sampled
SDA and SCL Falling Time	t <sub>F</sub>	—	—	0.3	μs	3.0-5.5V	periodically sampled
Stop Condition Setup Time	t <sub>SU:STO</sub>	0.6	—	—	μs	3.0-5.5V	—
Output Valid from Clock	t <sub>AA</sub>	—	—	0.9	μs	3.0-5.5V	—
Input Filter Time Constant (SDA and SCL pin)	t <sub>SP</sub>	—	—	50	ns	3.0-5.5V	Noise suppression time



## 14 Package Information

### 14.1 SOP24 (300mil) (15.40mm×7.5mm PP=1.27mm)

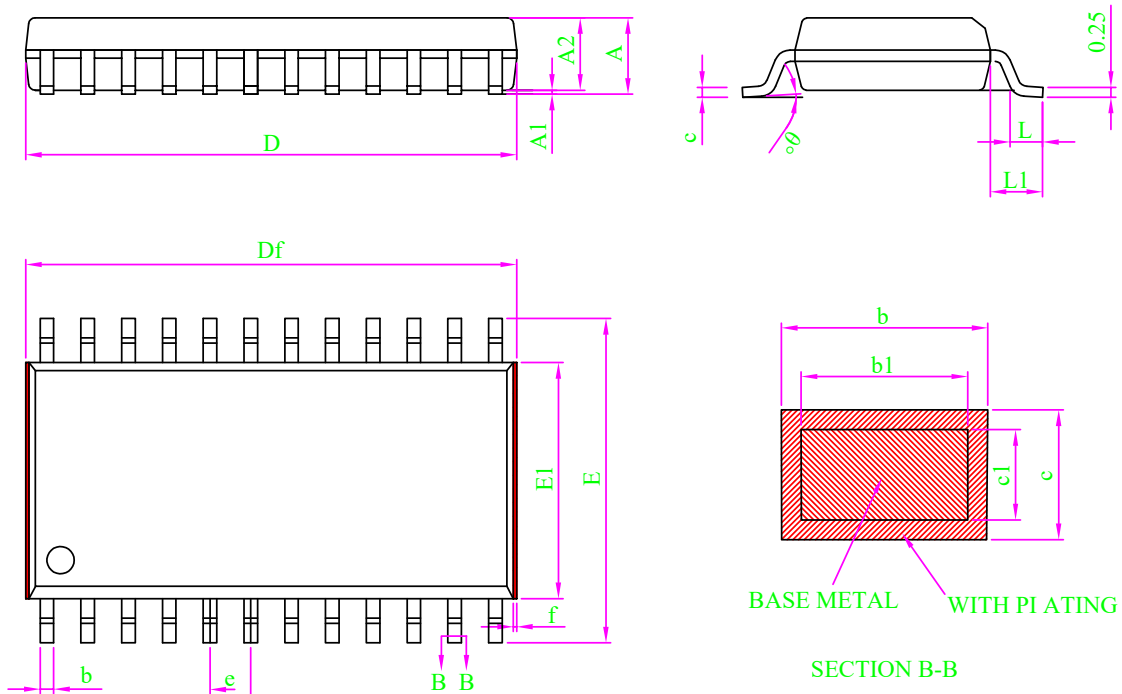

Note:

1. All dimension are in m
2. Dim D&E1 does not include plast flash; Df includes plastic flash(f);  
Flash: Plastic residual around body edge after de junk/singulation.
3. Dim b does not include damb protrusion/intrusion.
4. Plating thickness 0.007mm-0.020mm

SYMBOL	MILLIMETER		
	MIN	NOM	MAX
A	-	-	2.64
A1	0.10	0.15	0.20
A2	2.24	2.34	2.44
b	0.39	-	0.47
b1	0.38	0.41	0.43
c	0.25	-	0.30
c1	0.24	0.25	0.26
D	15.19	15.29	15.38
Df	15.29	-	15.79
E	10.10	10.30	10.50
E1	7.40	7.50	7.60
e	1.27 BSC		
L	0.71	0.86	1.01
L1	1.30	1.40	1.50
$\theta$	0	-	8°
f	0.05	-	0.20

## 15 Disclaimer

**Warranty and liability** — The information provided in this document is believed to be accurate and reliable. However, Shenzhen Vinka Microelectronics Co., Ltd. (hereinafter “the Company”) makes no warranties, express or implied, as to the completeness or suitability of this information for any specific purpose.

In no event shall the Company be liable for any indirect, incidental, or consequential damages, including but not limited to loss of profits, equipment damage, or system failure, arising out of the use of this product or documentation, regardless of the legal theory under which such liability is asserted.

**Right to change** — The Company reserves the right to modify any information contained herein without prior notice. The latest version of this document is available at:

<https://www.szvinka.com/>

**Applicability** — This product is not designed or intended for use in life-critical, medical, or safety systems where failure could result in injury or death. The customer shall assume full responsibility for any such use.

**Application** — All product application descriptions provided herein are intended for illustrative purposes only. The Company makes no representations or warranties, express or implied, regarding the suitability of any specific application without further testing or modification.

The customer is solely responsible for determining whether the Company’s products are appropriate for their intended applications or end customers.

The customer shall ensure proper design practices, implementation safeguards, and operational validation to minimize risks associated with product use.

The Company shall not be held liable for any defects, losses, costs, or damages arising from weaknesses or failures in the customer’s own products or applications, or from the integration or use of third-party products.

Furthermore, the customer shall conduct all necessary testing and validation for any third-party deployment of the Company’s products to avoid potential misuse or associated damages. The Company assumes no liability in this regard.

**Commercial terms of sale** — Unless otherwise agreed in writing, sales of this product are subject to the Company’s standard terms and conditions of sale. The Company expressly rejects the applicability of the customer’s general terms and conditions.

**Export control** — This product may be subject to applicable export control regulations. The customer is solely responsible for compliance with such regulations, including obtaining any necessary export licenses.

## 16 Revision History

No.	Version	Date	Modify the content	Check
1	1.0	2018-08-10	Initial release	YES
2	1.1	2018-10-11	Add reference circuit	YES
3	1.2	2019-03-21	Alignment correction	YES
4	1.3	2025-06-19	Change Description	YES

[1] Please refer to the latest version of this document before starting or finalizing any design.

[2] Since the release of this document, the status or availability of this product may have changed. For the most up-to-date information, please visit:

<https://www.szvinka.com/>