

Features

- Operating voltage 3.0-5.5V
- Built-in RC oscillator
- 8 SEG pins, 12GRID pins
- SEG pins connect to LED Anode , GRID pins connect to LED Cathode
- 2-wire serial interface
- 8-level brightness control
- Built-in 8×12 bit display RAM
- Power-On Reset(POR)

- Package:
SSOP24(150mil)(8.65mm × 3.90mm PP=0.635mm)

1 General Description

VK1640B is a RAM Mapping LED display driver, LED display numbers in the device is 96 patterns (8SEG x 12COM). SEG pins connect to LED Anode, GRID pins connect to LED Cathode. It is suitable for small LED display driver. SSOP24 package.

2 Pinouts and pin description

2.1 VK1640B SSOP24 Pin Assignment

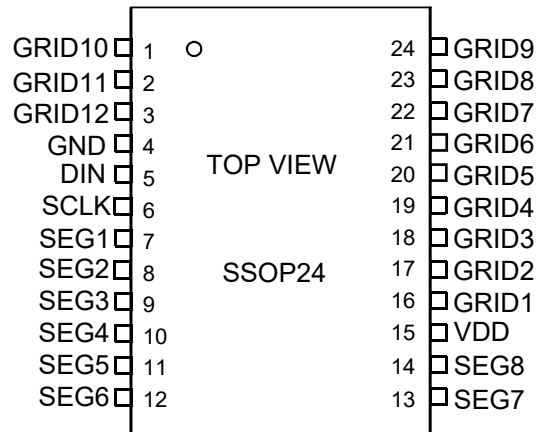

2.2 VK1640B SSOP24 Pin Description

No.	Name	I/O	Function
1-3 16-24	GRID1-GRID12	O	LED GRID outputs (N-MOS open drain)
4	GND	GND	Negative power supply
5	DIN	I	Serial data input, the data changes at the low level of SCLK and is transmitted at the high level of SCLK.
6	SCLK	I	Serial clock input, Read the input data to the display RAM on the rising edge.
7-14	SEG1-SEG8	O	LED SEG outputs (P-MOS open drain)
15	VDD	VDD	Positive power supply

3 Functional Description

3.1 Block diagram

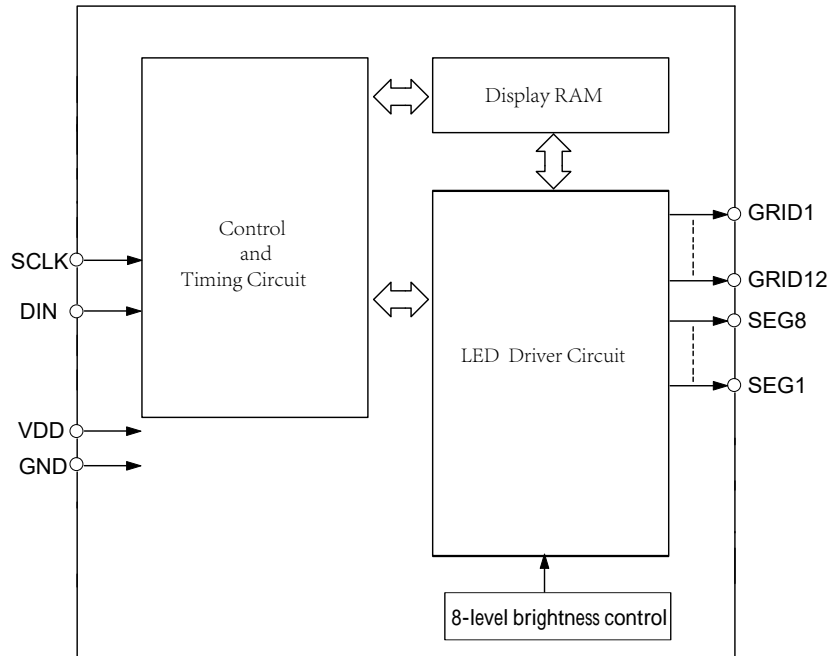

3.2 Display RAM

The static display memory (RAM) is organized into 8×12 bits and stores the displayed data. The contents of the RAM are directly mapped to the contents of the LCD driver. Display address is 0xC0-0xCB, the RAM size is 12 bytes. If you want to lighted on or off an LED, only set or clear the corresponding display RAM bit to 1 or 0, For example, if LED1 driven by SEG1 pin and GRID1 pin is on or off, only set bit0 to 1 or 0 of the corresponding display RAM (0xc0). The ram bit corresponding to the unused SEG pin is cleared to 0.

The following is a mapping from the RAM to the LED pattern:

SEG	SEG8	SEG7	SEG6	SEG5	SEG4	SEG3	SEG2	SEG1	Address
GRID1								LED1	0xC0
GRID2									0xC1
GRID3									0xC2
GRID4									0xC3
GRID5									0xC4
GRID6									0xC5
GRID7									0xC6
GRID8									0xC7
GRID9									0xC8
GRID10									0xC9
GRID11									0xCA
GRID12									0xCB
	D7	D6	D5	D4	D3	D2	D1	D0	

Note:

At the initial system power on, the value stored in the chip display RAM may be random. It is recommended to clear the display RAM after power on, write 0x00 to the all display RAM (0xc0-0xcb).

SEG pins connect to LED Anode, GRID pins connect to LED Cathode, Reverse connection is not allowed.

3.3 Serial Communication Command

3.3.1 Communication Interfacing

2 lines are required to interface with the VK1640B.

The SCLK line is the clock input, the data on the DATA line are Transmitted into the VK1640B on the rising edge of the SCLK signal.

The DIN pin is the serial data input, data changes at the low level of SCLK and is transmitted at the high level of SCLK. The starting condition is that when SCLK high, DIN changes from high to low; The end condition is that when SCLK is high, DIN changes from low to high.

3.3.2 Command Format

Command is used to set the Display Mode or write the Display Data.

After Start signal, the first byte input by DIN is used as the command byte, After decoding, Bit7 and bit6 of the byte are the command bits, as shown in the following table:

bit7	bit6	Command Function
0	1	Data Write Set Command
1	0	Display Control Command
1	1	Address Set Command

3.3.3 Command Description

3.3.3.1 Data Write Set Command

This command is used to write Display data and related commands. Bit1 and bit0 bits are not allowed to be set to 01 or 11.

when powered on, bit3-bit0 data is 0.

bit7	bit6	bit5	bit4	bit3	bit2	bit1	bit0	Function	Note
0	1	---				0	0	Write data	Write data to the RAM
0	1				0			Address mode set	address increase
0	1				1				address fixed
0	1			0				work mode set	normal mode
0	1			1					test mode

3.3.3.2 Address Set Command

Set the address of the Display RAM (0xc0 - 0xcb). When powered on, the address is set to 0xc0(default).

bit7	bit6	bit5	bit4	bit3	bit2	bit1	bit0	RAM Addresss
1	1	---		0	0	0	0	0xC0
1	1			0	0	0	1	0xC1
1	1			0	0	1	0	0xC2
1	1			0	0	1	1	0xC3
1	1			0	1	0	0	0xC4
1	1			0	1	0	1	0xC5
1	1			0	1	1	0	0xC6
1	1			0	1	1	1	0xC7
1	1			1	0	0	0	0xC8
1	1			1	0	0	1	0xC9
1	1			1	0	1	0	0xCA
1	1			1	0	1	1	0xCB

3.3.3.3 Display Control Command

Set the Display ON or OFF and select the Display brightness (level 8).

bit7	bit6	bit5	bit4	bit3	bit2	bit1	bit0	Function	Note		
1	0	---			0	0	0	Set Output Pulse Width	1/16 duty		
1	0				0	0	1		2/16 duty		
1	0				0	1	0		4/16 duty		
1	0				0	1	1		10/16 duty		
1	0				1	0	0		11/16 duty		
1	0				1	0	1		12/16 duty		
1	0				1	1	0		13/16 duty		
1	0				1	1	1		14/16 duty		
1	0				0					Display on/off	Display off
1	0				1					Display on/off	Display on

3.3.4 Command Timing Diagrams

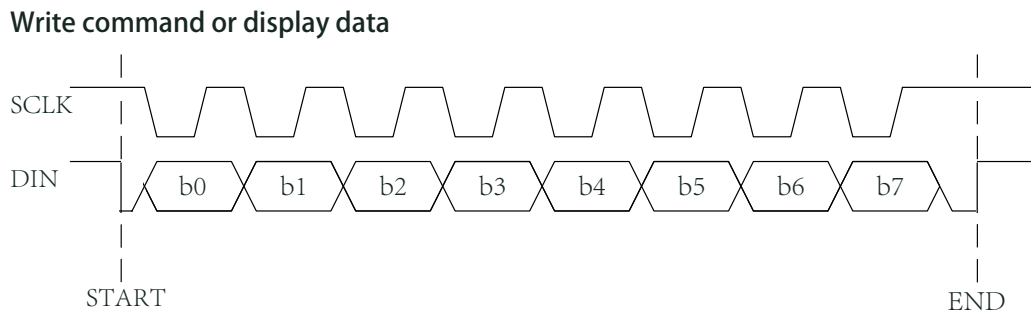

4 Command application

4.1 Send Display data(Address auto Increment)

Using the address auto-increase mode, First set the starting address of the data to be transmitted (Display RAM address). After the start address command byte is sent, the display data is directly transmitted, up to 12 bytes.

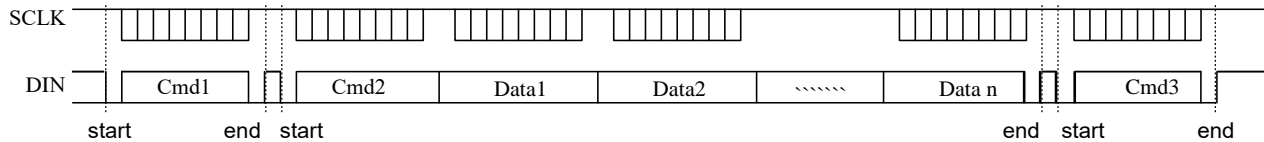

Cmd1: Data Write Set Cmd -Set address auto-increase mode (0x40)

Cmd2: Address Set Cmd -Set the start address of the display RAM (0xc0-0xcb)

Data1-Datan: Send display data to the start address set by CMD3 and the subsequent address (up to 12 bytes)

Cmd3: Display Control Cmd -Display ON and select the Display brightness

4.2 Send Display data(Fixed Address)

Using the fixed address mode, first set the address of the data to be transmitted (Display RAM address), After sending the address, directly transmit 1 byte of display data; Then transfer the address of the next display data, and directly transfer 1 byte of display data Until the last byte of display data is transmitted, Up to 12 bytes.

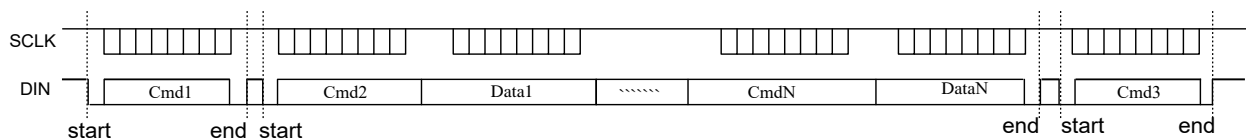

Cmd1: Data Write Set Cmd -Set fixed address mode (0x44)

Cmd2: Address Set Cmd -Set Display RAM address (0xC0-0xCB)

Data1: Send the Display data to the display RAM address set by Cmd2

CmdN: Address Set Cmd -Set Display RAM address (0xC0-0xCB)

DataN: Send the Display data to the display RAM address set by CmdN

...up to 12 bytes of data to be send

Cmd3: Display Control Cmd -Display ON and select the Display brightness

5 Application Circuits

8-SEG LED Display shared Cathode

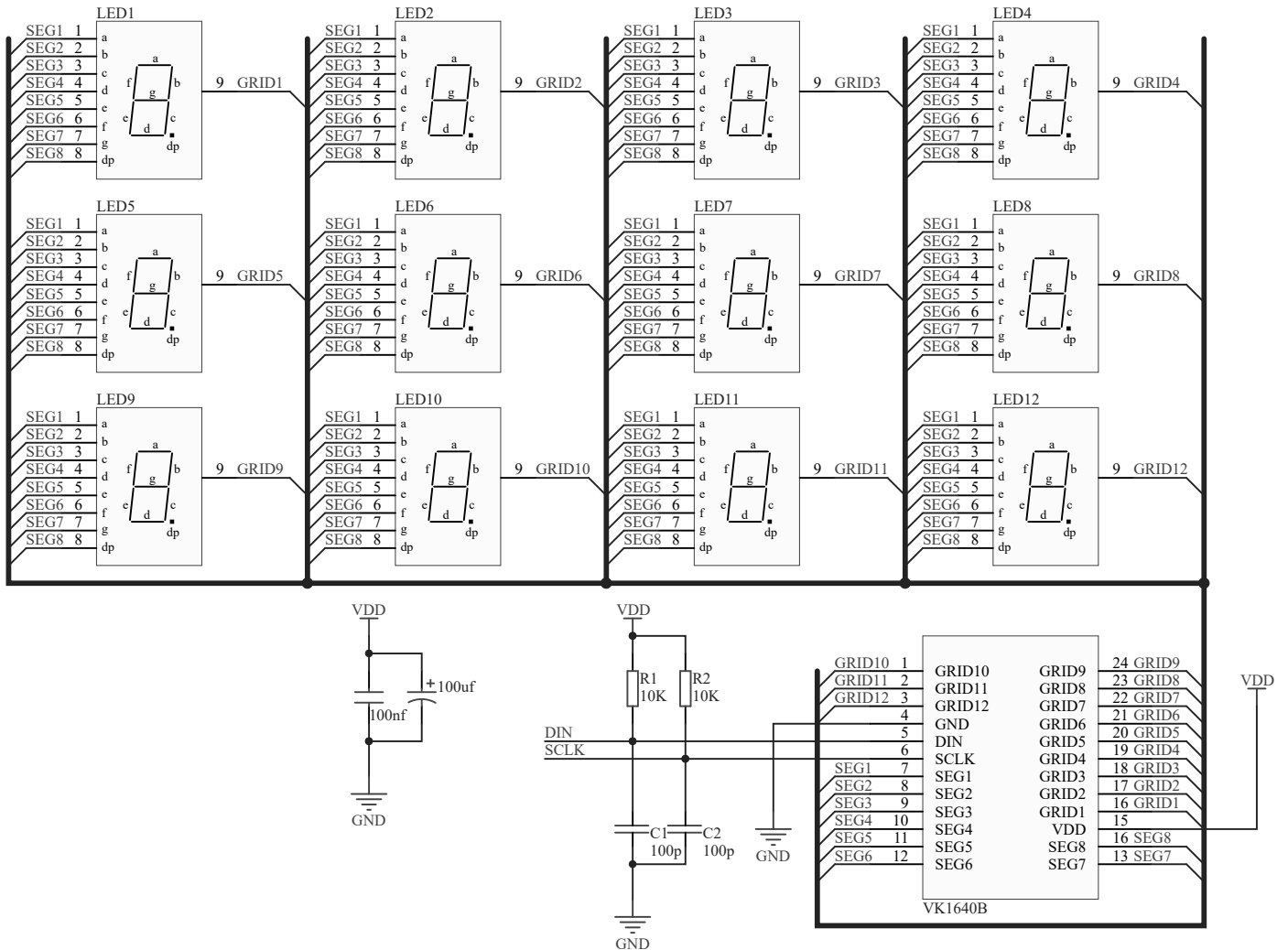

6 Electrical characteristics

6.1 Absolute Maximum Ratings

Item	Symbol	Ratings	Unit
Power voltage	VDD	-0.5~6.0	V
Input Voltage	VIN	$V_{SS}-0.5 \sim V_{DD}+0.5$	V
Power Dissipation	PD	400	mW
Drive Output Current	I_{OLGRID}	+200	mA
	I_{OHSEG}	-50	mA
Storage Temperature	TSTG	-65~+150	°C
Operating Temperature	TOTG	-40~+85	°C

6.2 DC Characteristics

Item	Symbol	Min.	Typ.	Max.	Unit	Test Conditions	
						VDD	Conditions
Power Supply Current	VDD	3.0	—	5.5	V	—	—
Quiescent Current	I_{DD}	—	—	0.1	mA	5V	No load/LED OFF
High Level output Current	I_{OH1}	-20	-25	-40	mA	5V	VO=VDD-2V SEG1~SEG8
	I_{OH2}	-20	-30	-50			VO=VDD-3V SEG1~SEG8
Low Level input Current	I_{OLGRID}	80	140	—	mA	5V	VO=0.3V GRID1- GRID16
Input Low Voltage	V_{IL}	0	—	0.3	VDD	VDD	SCLK, DIN
Input High Voltage	V_{IH}	0.7	—	1.0			
Hysteresis Voltage	V_H	—	0.35	—	V	5V	SCLK, DIN

6.3 AC Characteristics

Switch Parameters

Item	Symbol	Min.	Typ.	Max.	Unit	Test Conditions
oscillation frequency	F_{osc}	-	500	-	KHz	
Transmission delay time	t_{PLZ}	-	-	300	nS	CLK → DOUT
	t_{PZL}	-	-	100	nS	CL = 15pF, RL = 10K Ω
Rise Time	$t_{ZH 1}$	-	-	2	μS	CL=300pF SEG1-SEG16 GRID1-GRID8
	$t_{TZH 2}$	-	-	0.5	μS	CL=300pF GRID1-GRID8
Fall Time	t_{THZ}	-	-	120	μS	CL = 300pF SEGn,GRIDn
Max. input Freq	F_{MAX}	-	-	1	MHz	Duty50%
Input Capacitance	C_i	-	-	15	pF	-

Timing Parameters

Item	Symbol	Min.	Typ.	Max.	Unit	Test Conditions
Clock pulse width	PW_{CLK}	400	-	-	nS	-
Data Setup Time	t_{SETUP}	100	-	-	nS	-
Data Hold Time	t_{HOLD}	100	-	-	nS	-
Wait Time	T_{wait}	1	-	-	μS	CLK ↑ → CLK ↓

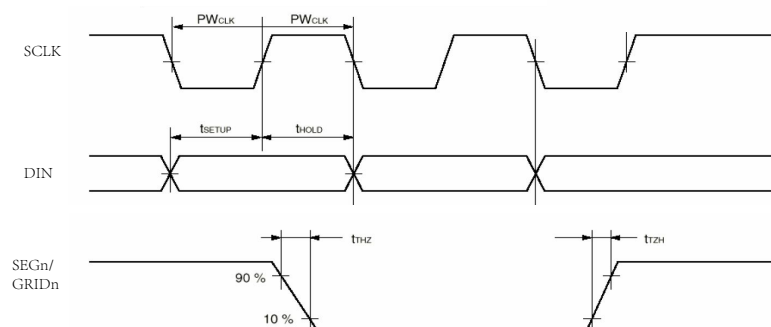

7 Package Information

7.1 SSOP24 (150mil)(8.65mm × 3.90mm PP=0.635mm)

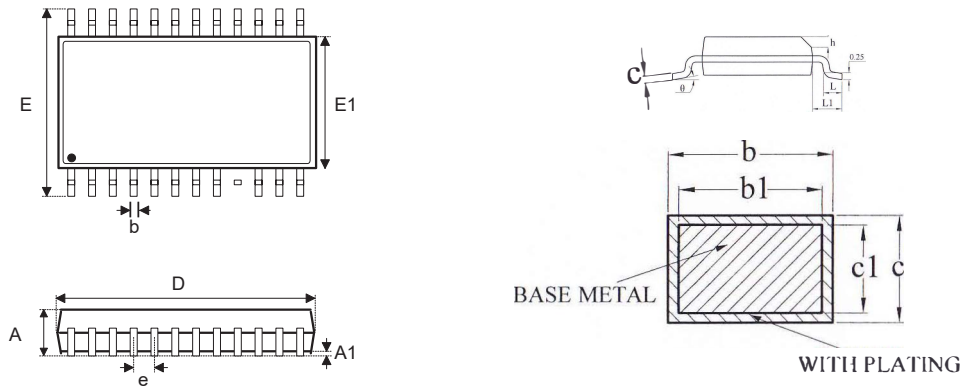

SYMBOL	MILLIMETER		
	MIN	NOM	MAX
A	—	—	1.75
A1	0.10	0.15	0.25
b	0.23	—	0.31
b1	0.22	0.25	0.28
c	0.20	—	0.24
c1	0.19	0.20	0.21
D	8.55	8.65	8.75
E	5.80	6.00	6.20
E1	3.80	3.90	4.00
e	0.635BSC		
h	0.30	—	0.50
L	0.50	—	0.80
L1	1.05REF		
θ	0	—	8°

8 Revision history

No.	Version	Date	Modify the content	Check
1	1.0	2018-08-10	Original version	Yes
2	1.1	2019-07-11	Add Ref circuits	Yes
3	1.2	2020-02-11	Update content	Yes

Disclaimers

Information in this document is believed to be accurate and reliable. However, VinKa does not give any representations or warranties, expressed or implied, as to the accuracy or completeness of such information. VinKa reserves the right to make changes to information published in this document, including without limitation specifications and product descriptions, at any time and without notice. This document supersedes and replaces all information supplied prior to the publication hereof. For the latest information, please visit <https://www.szvinka.com> Or contact VinKa's staff.