

## Features

- Operating voltage:2.0-5.5V
- Standby current: 1.5uA/3V
- Operating current: 4.0uA/3V
- Key Response Time: Normal Mode 60mS , Standby Mode 220mS
- AHLB pin selects the output level: Active level- high or Active level- low
- TOG pin selects the output mode: Direct output or Latch output
- Add a capacitor (0-50pF) to a touch key pin can fine tune the sensitivity for single key
- After power-on have about 0.5S stable-time, during the time do not touch the key .
- Auto-calibration Function
  
- Package  
SOT23-6L(3mm x 3mm PP=0.95mm)

## 1 General Description

VKD223EB is a touch pad detector IC which offers 1 touch keys, It can detect human body contact using external touch pads. The high level of device integration enable applications to be implemented with a minimum number of external components.

It has 1 Output pin, the output level, output mode can be selected through IO pin. Built in special voltage stabilizing circuit for touch detection is also employed to reduce the possibility of false detections.

With auto-calibration, low standby current, excellent resistance to voltage fluctuation and other features, this range of touch key devices provide a simple and effective means of implementing 1 touch key + IO operation in a wide variety of applications.

## 2 Pinouts and pin description

### 2.1 VKD223EB SOT23-6 Pin Assignment

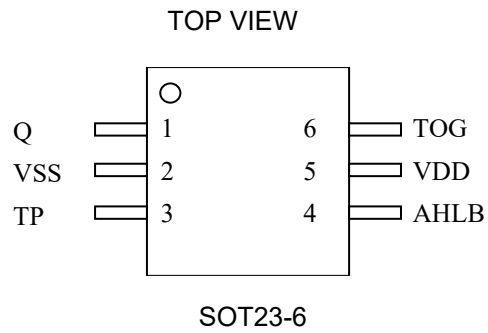

## 2.2 VKD223EB SOT23-6L Pin Description

Pin No.	Pin name	I/O	Function Description
1	Q	OUT	Touch key output pin
2	VSS	VSS	Negative power supply
3	TP	IN	Touch key input pin, Add a capacitor (0-50pF) to a touch key pin can fine tune the sensitivity
4	AHLB	IN—PL	Selects the output level: 1->Active level- low, 0->Active level- high(default)
5	VDD	VDD	Positive power supply
6	TOG	IN—PL	Selects the output mode: 1->Latch output, 0->Direct output(default)

Notes:

IN-PL: CMOS Input built-in pull-down resistor

## 3 Functional Description

### 3.1 Block diagram

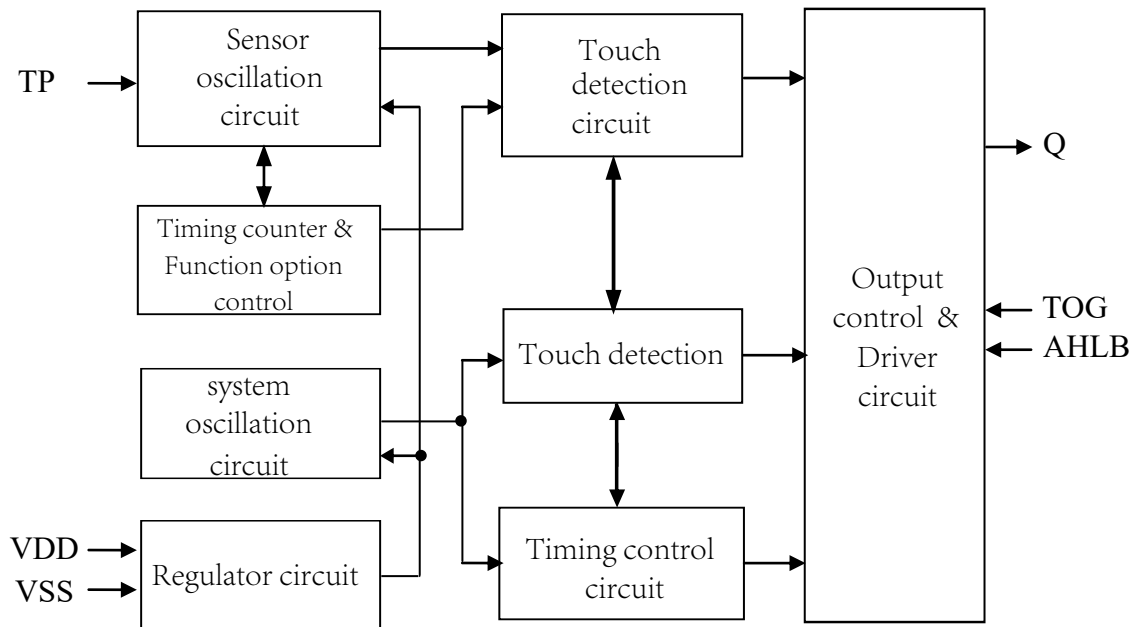

### 3.2 Auto-calibration Function

After power on, the environmental change system automatically calibrates the reference value.

### 3.3 Output mode

VKD223EB output pin is Q, output function can be selected by input pin.

TOG	AHLB	Output Function
NC	NC	CMOS direct output, active level- high
NC	VDD	CMOS direct output, active level- low
VDD	NC	CMOS latch output, power-on output 0
VDD	VDD	CMOS latch output, power-on output 1

### 3.4 Operating modes

There are two operating modes for VKD223EB, the normal mode and the standby mode. In normal mode, the response speed is faster and the power consumption is higher. In standby mode, power consumption is reduced, and the response speed will be slower when first touched. After that, the response speed will be the same as the normal working mode. Automatically switch to normal mode to work. If no key is pressed within 12s, it enter the standby mode.

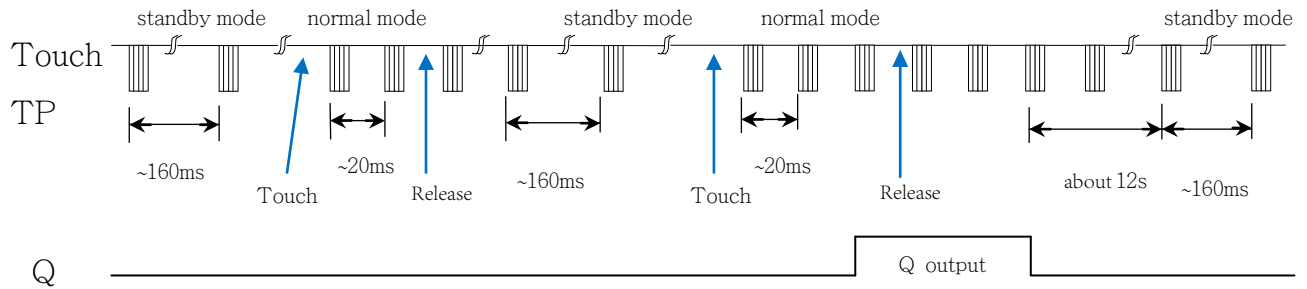

### 3.5 Sensitivity Adjustment

The touch PAD size and capacitance of connecting line on PCB can affect the sensitivity. The sensitivity adjustment must according to the practical application on PCB. The VKD223EB offers some methods for adjusting the sensitivity outside:

- I. Touch PAD Size  
Under other conditions are fixed. Using a larger Touch PAD size can increase sensitivity. Otherwise it can decrease sensitivity. But the touch PAD size must use in the effective scope.
- II. Panel Thickness  
Under other conditions are fixed. Using a thinner panel can increase sensitivity. Otherwise it can decrease sensitivity. But the panel thickness must be below the maximum value.
- III. Capacitor to a touch key pin  
Add a capacitor (0-50pF(NPO,X7R)) to a touch key can fine tune the sensitivity for single key, When adding the value of capacitor will decrease sensitivity



## 4 Application Circuits

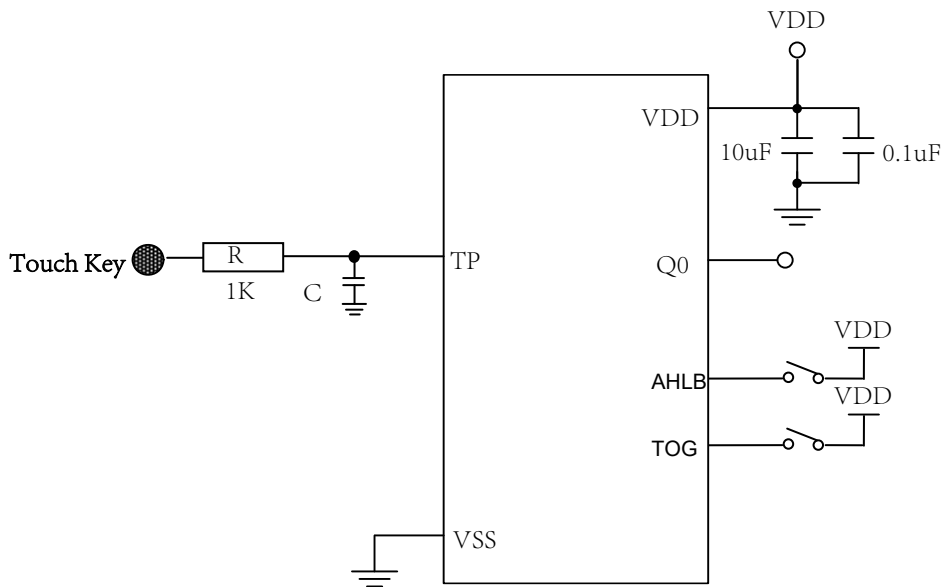

### Precautions:

1. On the PCB, the wire length from the touch pad to the IC pin should be as short as possible. And this wiring shall not be parallel or cross with other lines.
2. The power supply must be stable. If the voltage of the power supply drifts or drifts or shifts rapidly, it may cause abnormal sensitivity or false detection.
3. The board covered on the PCB must not contain metal or conductive components, and the surface coating is the same.
4. A capacitor must be connected in series between VDD and VSS; and the wiring with the shortest distance from the VDD and VSS pins of the device IC should be taken.

## 5 Electrical characteristics

### 5.1 Absolute Maximum Ratings

Item	Symbol	Ratings	Unit
Power voltage	VDD	-0.3~6.0	V
Input Voltage	VIN	$V_{SS}-0.3 \sim V_{DD}+0.3$	V
Storage Temperature	TSTG	-50~+125	°C
Operating Temperature	TOTG	-40~+85	°C
Human Body Mode	ESD	$\geq 4$	KV

### 5.2 DC Characteristics

Item	Symbol	Min.	Typ.	Max	Unit	Test Conditions (25 °C)	
						VDD	Conditions
Operating voltage	VDD	2.0	3.0	5.5	V	—	—
Operating current	$I_{OP}$	—	4.0	8.0	$\mu A$	3.0V	Operating mode
Standby current	$I_{ST}$	—	1.5	3.0	$\mu A$	3.0V	Standby mode
Output Sink Current	$I_{IL}$	—	8	—	mA	3.0V	$V_{OL}=0.6V$
		—	16	—		5.0V	
Output Source Current	$I_{OL}$	—	-4	—	mA	3.0V	$V_{OH}=2.4V$
		—	-8	—		5.0V	$V_{OH}=4.4V$
Input Low Voltage	$V_{IL}$	—	—	0.2	VDD	VDD	Input Low Voltage
Input high Voltage	$V_{IH}$	0.8	—	1	VDD	VDD	Input High Voltage
Input pull-low resistor	$R_{PL}$	—	28k	—	ohm	3.0V	VDD=3V
Output Response Time	$T_R$	—	60	—	mS	3.0V	Operating mode
		—	60	—		5.0V	Operating mode
		—	220	—	mS	3.0V	Standby mode
		—	220	—		5.0V	Standby mode

## 6 Package Information

### 6.1 SOT23-6L(3mm x3mm PP=0.95mm):

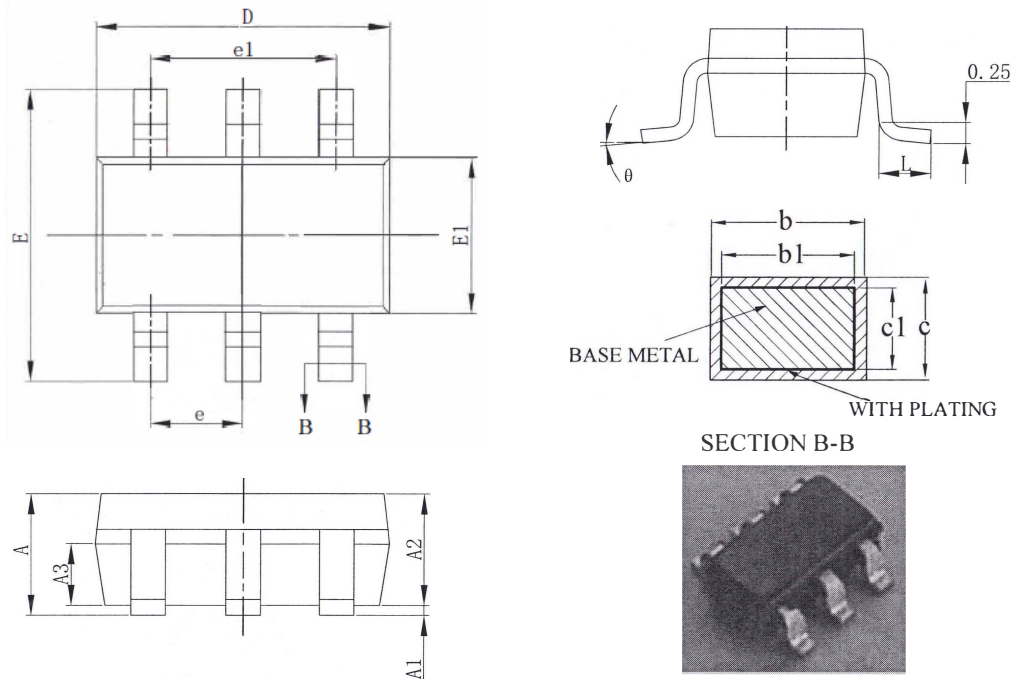

SYMBOL	MILLIMETER		
	MIN	NOM	MAX
A	---	---	1.25
A1	0.04	---	0.10
A2	1.00	1.10	1.20
A3	0.55	0.65	0.75
b	0.38	---	0.48
b1	0.37	0.40	0.43
c	0.11	---	0.21
c1	0.10	0.13	0.16
D	2.72	2.92	3.12
E	2.60	2.80	3.00
E1	1.40	1.60	1.80
e	0.95BSC		
e1	1.90BSC		
L	0.30	---	0.60
$\theta$	0	---	8°

## 7 Revision history

No.	Version	Date	Modify the content	Check
1	1.0	2019-12-10	Original version	Yes
2	1.1	2020-05-11	Update version	Yes

### Disclaimers

Information in this document is believed to be accurate and reliable. However, VinKa does not give any representations or warranties, expressed or implied, as to the accuracy or completeness of such information. VinKa reserves the right to make changes to information published in this document, including without limitation specifications and product descriptions, at any time and without notice. This document supersedes and replaces all information supplied prior to the publication hereof. For the latest information, please visit <https://www.szvinka.com> Or contact VinKa's staff.