



VK36N7B Datasheet

7-channel touch 3-digit BCD code output

Rev.1.2

Intellectual Property Statement:

Shenzhen Vinka Microelectronics Co., Ltd. (hereinafter referred to as “the Company”) owns legally registered intellectual property rights in both domestic and international jurisdictions. Any unauthorized use of the Company’s products or patented technologies by individuals or organizations is strictly prohibited.

The Company reserves the right to take legal action against any infringement, and to seek full compensation for damages or unlawful gains.

The Company’s name and trademarks are legally protected and may not be used or imitated without explicit written permission. No implied or express license shall be granted under any circumstances.

1 General Description

The VK36N7B has 7 touch buttons, which can be used to detect the touch actions of human hands on the external touch buttons. This chip has a high degree of integration and only requires a few external components to achieve the detection of touch buttons.

It provides a 3-bit BCD code output function, 1 touch status output pin, and can be selected through the IO pin to output the power-on level and output mode - latch or direct output. The chip internally adopts a special integrated circuit, with a high power supply voltage suppression ratio, which can reduce the occurrence of key detection errors and ensure the high reliability of the chip in adverse environmental conditions.

This touch chip has an automatic calibration function, low standby current, and anti-voltage fluctuation characteristics. It provides a simple and effective implementation method for various touch buttons + BCD code output applications.

2 Key Features

- Operating voltage: 2.2-5.5V
- Standby current 10 μ A/3.0V
- Power-on reset function (POR)
- Low-voltage reset function (LVR)
- Touch output response time: 48ms in operating mode, 160ms in standby mode
- Select the high or low voltage level of the power output through the AHLB pin.
- Select direct output or latch output through the TOG pin.
- Output 3-bit BCD output pin + touch status indication pin (OUTFLAG)
- Single key output is valid. The output occurs immediately upon touching, and no response will be given to other keys if the touch is not released.
- Anti-error function, maximum output time of the effective key: 13 seconds
- Touchless 4S enters standby mode
- Adjust overall sensitivity by connecting a ground capacitor to the CS pin (1-47nF)
- Each touch channel is independently connected to a small ground capacitor for fine-tuning sensitivity (0-50pF).
- The system is stable within 0.3 seconds after power-on, and no touching is allowed.
- When the power is turned on and no touch is detected, the environmental changes will automatically calibrate the reference value.
- Resistant to voltage fluctuations and has good anti-interference performance
- Available Packages:
 - SOP16(150mil)(9.9mm x 3.9mm PP=1.27mm)
 - QFN16L(3.0mm x 3.0mm PP=0.5mm)

3 Product Selection

Part No.	Voltage/Standby Current	Output	Packaging
VK36N3B	2.2V-5.5V/10 μ A(3.0V)	BCD Output	SOP8
VK36N4B	2.2V-5.5V/10 μ A(3.0V)	BCD Output	SOP16/QFN16L
VK36N5B	2.2V-5.5V/10 μ A(3.0V)	BCD Output	SOP16/QFN16L
VK36N6B	2.2V-5.5V/10 μ A(3.0V)	BCD Output	SOP16/QFN16L
VK36N7B	2.2V-5.5V/10 μ A(3.0V)	BCD Output	SOP16/QFN16L
VK36N8B	2.2V-5.5V/10 μ A(3.0V)	BCD Output	SOP16/QFN16L

4 Ordering Information

Part No.	Packaging	Tube Qty	Tray(reel)Qty	Box Qty	Total Qty	Notes
VK36N3B	SOP8	100/tube		10000/box	100000 PCS	
VK36N4B	SOP16	50/tube		5000/box	50000 PCS	
	QFN16L		3000/reel	30000/box	120000 PCS	
VK36N5B	SOP16	50/tube		5000/box	50000 PCS	
	QFN16L		3000/reel	30000/box	120000 PCS	
VK36N6B	SOP16	50/tube		5000/box	50000 PCS	
	QFN16L		3000/reel	30000/box	120000 PCS	
VK36N7B	SOP16	50/tube		5000/box	50000 PCS	
	QFN16L		3000/reel	30000/box	120000 PCS	
VK36N8B	SOP16	50/tube		5000/box	50000 PCS	
	QFN16L		3000/reel	30000/box	120000 PCS	

5 Package Pinout Information(SOP16/QFN16L)

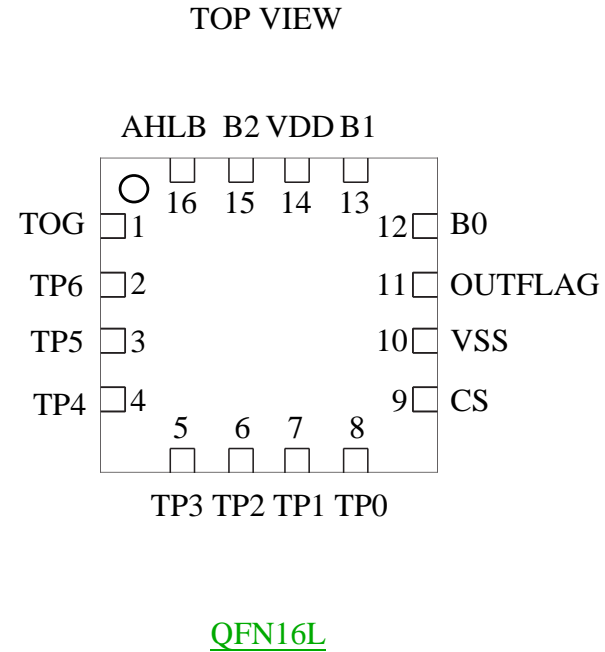
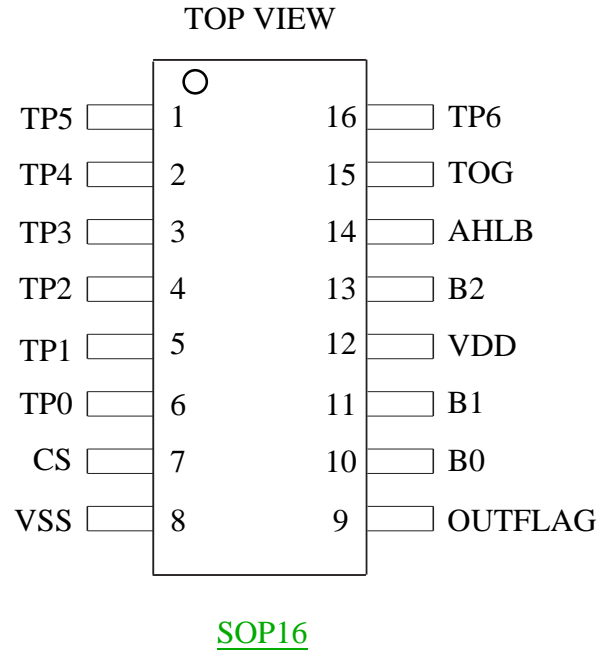

For more information: Page 11-12

5.1 VK36N7B/SOP16/QFN16L Pin Description

Pin Names		I/O	Function Description
SOP16	QFN16L		
1-TP5	3-TP5	I	Touch input. Connect a ground capacitor to fine-tune the sensitivity (1-50pF). No connection results in the highest sensitivity.
2-TP4	4-TP4	I	Touch input. Connect a ground capacitor to fine-tune the sensitivity (1-50pF). No connection results in the highest sensitivity.
3-TP3	5-TP3	I	Touch input. Connect a ground capacitor to fine-tune the sensitivity (1-50pF). No connection results in the highest sensitivity.
4-TP2	6-TP2	I	Touch input. Connect a ground capacitor to fine-tune the sensitivity (1-50pF). No connection results in the highest sensitivity.
5-TP1	7-TP1	I	Touch input. Connect a ground capacitor to fine-tune the sensitivity (1-50pF). No connection results in the highest sensitivity.
6-TP0	8-TP0	I	Touch input. Connect a ground capacitor to fine-tune the sensitivity (1-50pF). No connection results in the highest sensitivity.
7-CS	9-CS	I	Sensitivity adjustment, connecting ground capacitor (1-47nF)
8-VSS	10-VSS	VSS	Negative power supply
9-OUTFLAG	11-OUTFLAG	O	Touch status output
10-B0	12-B0	O	Touch output
11-B1	13-B1	O	Touch output
12-VDD	14-VDD	VDD	Positive power supply
13-B2	15-B2	—	Touch output
14-AHLB	16-AHLB	I	Select output level: Open circuit -> Low level is valid, VSS -> High level is valid
15-TOG	1-TOG	I	Select output mode: Suspended -> Direct Output, VSS -> Latched Output
16-TP6	2-TP6	I	Touch input. Connect a ground capacitor to fine-tune the sensitivity (1-50pF). No connection results in the highest sensitivity.

6 Functional Description

6.1 Block Diagram

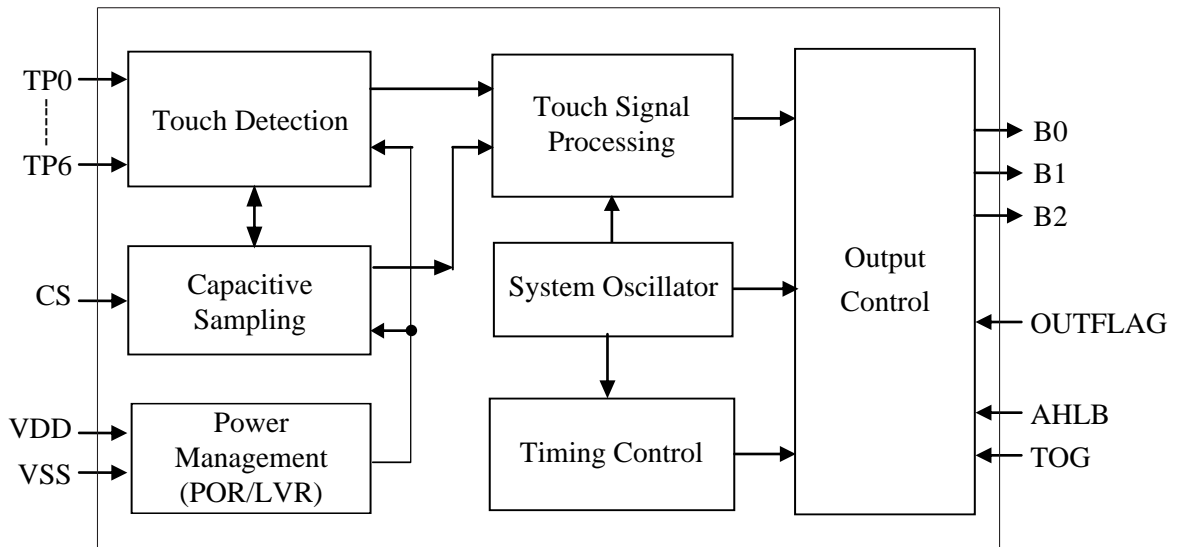

6.2 Automatic Calibration

After power-on, the chip will perform initialization and obtain the first reference value. Subsequently, when there is no touch, the touch chip will automatically calibrate the reference value, enabling the reference value to dynamically change according to the external environment.

For example, this mechanism can achieve reliable touch detection when there is a temperature change or environmental noise.

6.3 Anti-Calcification Function

To minimize unintended key presses such as accidental contact with the sensing electrodes, a maximum key duration function is set within the chip. When a touch key is pressed, the internal timer starts timing. If the pressing time exceeds approximately 13 seconds, the touch chip will ignore the state of the touched key, recalibrate, obtain a new reference value, and reset the status to the initial state upon power-on.

6.4 Resistance To Voltage Fluctuations

The chip is equipped with an anti-voltage fluctuation function, which can prevent the occurrence of touch button malfunction caused by the sudden drop in working voltage due to the large current drive from the peripheral devices.

6.5 Output Mode

The output of VK36N7B is B0 to B2, in CMOS format. The valid output level can be selected by the state of the AHLB pin during power-on, and the output mode can be selected by the state of the TOG pin during power-on.

The OUTFLAG pin outputs the touch status. When there is a touch, the output level changes; when there is no touch, the output level returns to the state at power-on.

AHLB	Select the output of the valid level	TOG	Select the output method
NC	Low level is valid. Power-on output is 1.	NC	Direct output
VSS	High level is valid. Power-on output is 0.	VSS	Latched output

Data format: OUTFLAG + 3-digit BCD code value.

AHLB is floating during power-on							
Touch Pin	BCD code		OUTFLAG	Touch Pin	BCD code		OUTFLAG
	TOG=VSS	TOG NC			TOG=VSS	TOG NC	
TP0 Touch	000	000	0	TP0 Release	000	111	1
TP1 Touch	001	001	0	TP1 Release	001	111	1
TP2 Touch	010	010	0	TP2 Release	010	111	1
TP3 Touch	011	011	0	TP3 Release	011	111	1
TP4 Touch	100	100	0	TP4 Release	100	111	1
TP5 Touch	101	101	0	TP5 Release	101	111	1
TP6 Touch	110	110	0	TP6 Release	110	111	1

Note: When powered on, the output level is BCD = 111 , OUTFLAG = 1.

When powered on, AHLB is connected to VSS							
Touch Pin	BCD code		OUTFLAG	Touch Pin	BCD code		OUTFLAG
	TOG=VSS	TOG NC			TOG=VSS	TOG NC	
TP0 Touch	111	111	1	TP0 Release	111	000	0
TP1 Touch	110	110	1	TP1 Release	110	000	0
TP2 Touch	101	101	1	TP2 Release	101	000	0
TP3 Touch	100	100	1	TP3 Release	100	000	0
TP4 Touch	011	011	1	TP4 Release	011	000	0
TP5 Touch	010	010	1	TP5 Release	010	000	0
TP6 Touch	001	001	1	TP6 Release	001	000	0

Note: When powered on, the output level is BCD = 000 , OUTFLAG = 0.

8 电气特性

8.1 极限参数

特性	符号	极限值	单位
电源电压	VDD	-0.3~6.0	V
输入电压	VIN	VSS-0.3~VDD+0.3	V
存贮温度	T _{STG}	-50~+125	
工作温度	T _{OTG}	-40~+85	
静电(HBM)	ESD	4KV-8KV(Class 3A)	KV

8.2 直流参数

名称	符号	最小值	典型值	最大值	单位	测试条件 (25)	
						VDD	条件
工作电压	VDD	2.2	3.0	5.5	V	—	—
低压复位	LVR	—	2.0	2.1	V	—	—
工作电流	I _{OP}	—	1.3	—	mA	3.0V	CS=10nF
		—	2.2	—		5.0V	
待机电流	I _{ST}	—	10	—	μA	3.0V	CS=10nF
		—	33	—		5.0V	
输出灌电流	I _{IL}	—	4	—	mA	3.0V	V _{OL} =0.6V
		—	8	—		5.0V	
输出源电流	I _{OL}	—	-2	—	mA	3.0V	V _{OH} =2.6V
		—	-4	—		5.0V	V _{OH} =4.3V
输入低电压	V _{IL}	—	—	0.3	VDD	VDD	输入低电压
输入高电压	V _{IH}	0.7	—	1	VDD	VDD	输入高电压
输入上拉电阻	R _{PH}	—	150k	—	ohm	3.0V	VDD=3V
输入下拉电阻	R _{PL}	—	50k	—	ohm	3.0V	VDD=3V
输出响应时间	T _R	—	45	—	mS	3.0V	工作模式
		—	48	—		5.0V	工作模式
		—	150	—	mS	3.0V	待机模式
		—	160	—		5.0V	待机模式

9 封装信息

9.1 SOP16(9.9mm x 3.9mm PP=1.27mm)

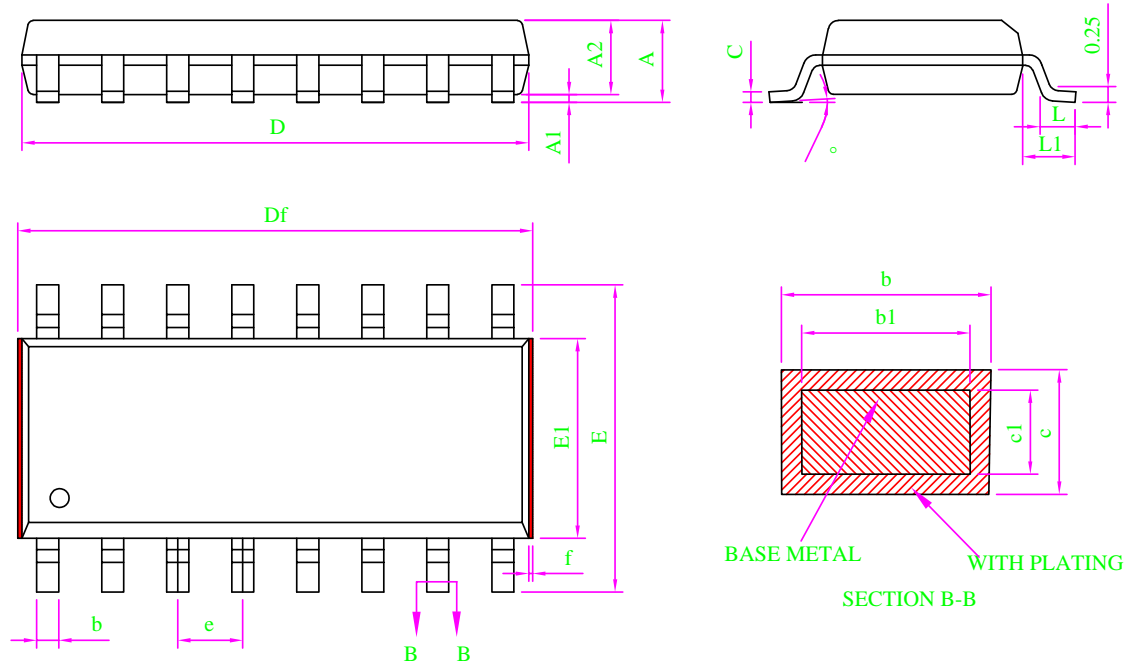

Note:

- All dimension are in mm.
Dim D&E1 does not include plastic flash; Df includes plastic flash(f);
Flash: Plastic residual around body edge after de junk/singulation.
- Dim b does not include dambar protrusion/intrusion.
- Plating thickness 0.007mm-0.020mm

MILLIMETER			
SYMBOL	MIN	NOM	MAX
A	-	-	1.75
A1	0.10	0.15	0.20
A2	1.35	1.45	1.55
b	0.39	-	0.47
b1	0.38	0.41	0.43
c	0.20	-	0.25
c1	0.19	0.20	0.21
D	9.80	9.90	10.00
Df	9.90	-	10.40
E	5.80	6.00	6.20
E1	3.80	3.90	4.00
e	1.27BSC		
L	0.51	0.66	0.81
L1	0.95	1.05	1.15
	0	-	8°
f	0.05	-	0.20

9.2 QFN16L(3.0mm x 3.0mm PP=0.5mm)

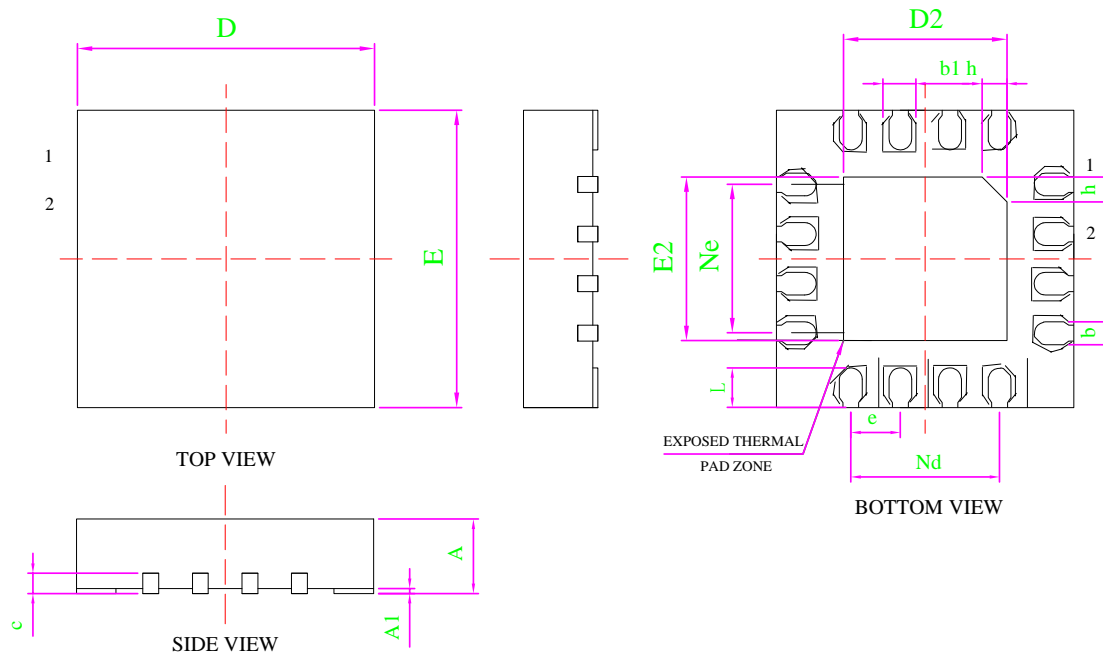

Dimensions			
SYMBOL	MIN	NOMINAL	MAX
A	0.70	0.75	0.80
A1	0	0.02	0.05
b	0.18	0.25	0.30
b1	0.30	0.35	0.40
c	0.18	0.20	0.25
D	2.90	3.00	3.10
D2	1.55	1.65	1.75
e	0.50BSC		
Ne	1.50BSC		
Nd	1.50BSC		
E	2.90	3.00	3.10
E2	1.55	1.65	1.75
L	0.35	0.40	0.45
h	0.20	0.25	0.30
L/F 载体尺寸 (miL)	75*75		

10 免责声明

保修和责任 —— 本文档中的信息是正确可靠的，但我公司对于这些信息的准确性和完整性不作任何保证。对于此类信息的使用后果不负任何责任。在任何情况下，深圳市永嘉微电科技有限公司(以下简称本公司)不会承担任何间接、意外发生、惩罚性的相关性的损害赔偿，不管这些损害赔偿是基于侵权（包括疏忽）、保修、违约合同或是其他法律理论。

变更的权利 —— 本公司有权在任何时间对此文件发布的信息做出任何改动。更改过的文件将会取代之前所有公布的信息。您可随时查看我们的官网：

<https://www.szvinka.com/>

适用性 —— 本公司的产品并非是为那些用于对生命和安全有重大关系的系统和设备而设计的。对于使用本公司的产品而导致的故障，造成的人身伤害、甚至死亡、或是严重的财产或环境损害的应用程序。如果本公司的产品应用在此类的设备或应用程序中，本公司对此造成的风险将不承担任何的责任，因此这些风险由客户自行承担。

应用 —— 在这里所有描述有关产品的任何应用程序仅用于说明的目的。在没有进一步测试或修改的情况下，本公司对该应用程序的指定用途是否合适不作任何表示或保证。本公司不负责协助应用程序或客户的产品设计。同时客户应自行负责决定我司的产品是否适合应用计划产品、计划的应用程序以及第三方客户的使用。

客户应适当的提供设计和运行，保障措施以尽量减少其产品与应用的相关风险。如果因客户的应用或产品的弱点或缺陷所产生的，或因使用其他第三方的产品而造成的任何缺陷、损失、费用支出等问题，本公司不承担任何责任。客户应负责为其使用本公司产品的第三方客户做必要的产品或应用的测试，以避免使用不当而造成不必要的损失。本公司对在此方面不承担任何责任。

商业销售条件 —— 本公司的产品销售条款适用于通用的商业销售条款。如有其他要求可另出一份单独有效的书面协议，在此种情况下，将适用该单独有效的书面协议条款和条件。关于客户采购本公司的产品，本公司在此明确拒绝适用客户的通用条款和条件。

出口控制 —— 本文档描述的产品以及其项目可能受出口管制条例限制。出口可能需事先获得国家机关许可。

11 历史版本

No.	版本	日期	修订内容	检查
1	1.0	2018-08-10	原始版本	YES
2	1.1	2020-02-11	添加参考电路	YES
3	1.2	2024-11-01	更新内容	YES

[1] 在开始或完成设计之前，请查阅最近发布的文件。

[2] 自本档发布以来，本档中描述的设备产品状态可能已经发生了变化，并且在多个情况下可能会有所不同。最新的产品状态信息可在互联网上查询，网址为 <https://www.szvinka.com/>